

TRAILER T-117/2

TECHNICAL SPECIFICATIONS | EQUIPMENT



 **HOMOLOGATION
EUROPEAN**



Year of model 2022

CynkoMet[®]
Czarna Białostocka

TECHNICAL SPECIFICATIONS	
Type/version/variant	T-3/510/111
Technically (design) permissible total weight rating	6,800 kg
Gross vehicle weight rating	6,800 kg
including on axles max.	5,800 kg
including on drawbar max.	1,000 kg
Load capacity	~5,180 kg*
Unladen mass	~1,620 kg*
Length	4,720 mm
Width	1,990 mm
Height without extension	~1,675 mm
Height with extension	~2,275 mm
Cargo box dimensions (length/width/height)	3,320 x 1,810 x 600 mm
Loading capacity - without extensions / with extensions	3.6 / 7.2 m ³
Height of floor above ground	1,075 mm
Tire size	11.5/80-15.3
Floor/wall sheet thickness	3/2.5
Track of wheels	1,500 mm
Drawbar coupling height - bottom position	445 mm
Drawbar coupling height - top position	770 mm
Max. tolerable vertical load on drawbar	1,000 kg
Transport/working speed	30 km/h
Suspension	rigid
Class of cooperating tractor	60 HP
Tipping angle of the cargo box (backward / sideways)	45/50

* - unladen weight and loading capacity may differ depending on the trailer's equipment

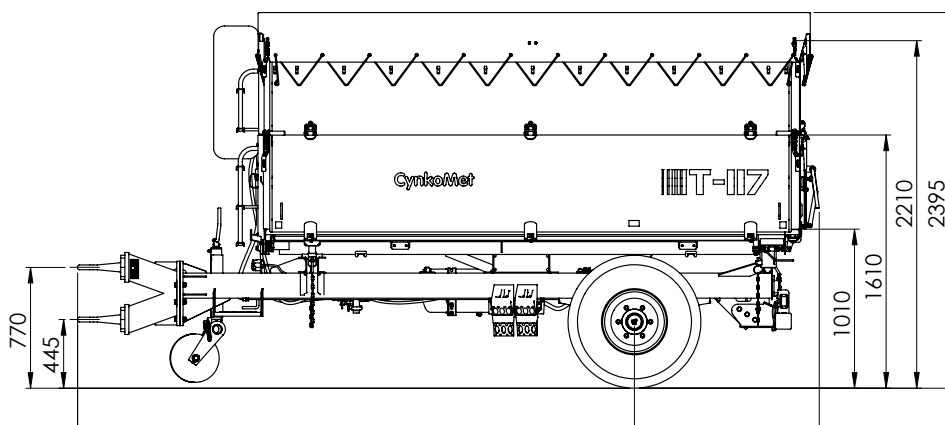
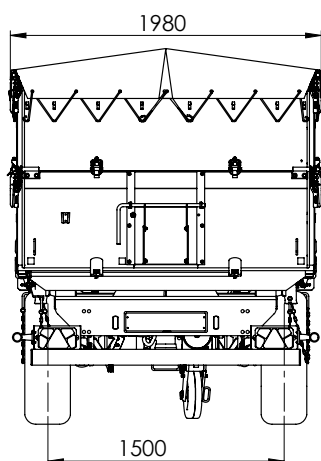

STANDARD MACHINE EQUIPMENT
Wall height 600 mm with thickness 2.5 mm, hot-galvanized
New 11.5/80-15.3 wheels
Rigid drawbar for coupling with the top or bottom hitch of the tractor, with replaceable 40mm eye, drawbar homologated according to Regulation 55UN ECE,
Homologated, hot-galvanized bumper
Axles from the renowned ADR company, homologated (EU 2015/68), bar cross-section - square 70, brake size 300x60 306E, 6 M18x1.5 pins
Central bolt-locking of walls (bottom sideboards)
Exterior ladder and steps inside cargo box - hot-galvanized - with anti-skid steps facilitating access to cargo box
Two wheel chocks placed in galvanized pockets
Telescopic actuator with articulated suspensions, four-level with 1,300 mm pitch. Useful force at fourth level with diameter 105mm, at nominal pressure 16MPa = 138kN (~14T)
Tipping installation protected against excessive box inclination by cut-off valve
Maintenance support of cargo box, hot-galvanized
Hot-galvanized frame of cargo box
Main stringers of cargo box frame made of 160x60x4 closed profiles
Galvanized cargo box floor made of single riveted and bolted sheet, thickness 3mm
Hot-dip galvanized bottom frame (protection of the structure on the exterior and interior of profiles), stringers of the frame made of metallurgical 160 channel sections, additionally closed by 5 mm-thick sheet
12V lighting, homologated, rear bulb lamps, LED perimeter lighting
Hydraulic tipping installation of cargo box made of galvanized steel tubes and flexible hoses
Hydraulic connectors to tractor, type ISO 7241-1 DN 12.5
Lighting installation connector cable with 7PIN 12V plug
Homologated, double-circuit, pneumatic brake system with manual braking force adjustment from HALDEX.
Parking handbrake with crank
Grain chute, hot-galvanized, with blockade in the rear wall
Straight drawbar support with partially collapsible steel wheel

All of our agricultural machines are designed and tested by our design team using the latest available tools. Manufacturing is performed with the greatest diligence and in adherence to rigorous quality standards.

OPTIONAL MACHINE EQUIPMENT

11.5/80-15.3 spare wheel

400/60-15.5 spare wheel

Surcharge for 400/60 - 15.5 wheels

Spare wheel hanger, hot-galvanized

Hot-galvanized 600 mm wall extensions, thickness 2.5 mm

Hot-galvanized mesh wall extensions, height 1000 mm

Chute for precise tipping, hot-galvanized

Laced tarpaulin

Hot-galvanized tarpaulin frame made of 40x40x3 closed profiles

Full LED lighting

Hydraulic quick-coupler with pressure neutralizer in hose

Warning triangle (sign distinguishing slow-moving vehicle)

Homologated, hydraulic brake system with manual braking force adjustment

Overrun braking system

DUPLEX - painted set of walls

DUPLEX - painted set of extensions



The data and photographs given in the catalog are for illustrative purposes only. This document and the information it contains, including prices, do not constitute a commercial offer within the meaning of art. 66 of the Civil Code. This information may be subject to change as products are continuously improved. The manufacturer reserves the right to change a product's characteristics at any time. Products' specifications may change without notice.



**HOT-
GALVANIZED CONSTRUCTION**

CynkoMet®
Czarna Białostocka