

CynkoMet Sp. z o.o.  
ul. Fabryczna 7 W  
16-020 Czarna Białostocka  
tel. (085) 710 24 56

## **TWO-AXLE TRACTOR TRAILER THREE-WAY TIPPER**

# **T-149**

## **INSTRUCTIONS FOR USE AND OPERATION**

### Identification of the machine

Symbol / Type T-149/1

Serial number:.....

The serial number is stamped on the nameplate and on the front beam of the upper frame of the trailer. The nameplate is riveted to the front beam of the upper frame.

When buying the trailer, check the conformity of the serial number stamped on the trailer with the serial number given in the warranty card, in the sales documents and in the instruction manual.

**CAUTION!**

The manufacturer reserves the right to introduce, in the manufactured machines, structural alterations facilitating servicing and improving the quality of their work. The information on significant design changes are communicated to the user by means of enclosed information (annexes).

Comments and observations about the design and operation of the machine should be sent to the manufacturer. This information will allow objective evaluation of the machine, and serve as guidelines in their further modernization.

**Before the operation, the user should be familiar with this manual and follow all recommendations. This will ensure safe maintenance and trouble-free operation of the machine.**

If the information contained in the manual will prove to be not fully understood, seek help at the sales point and ask where the machine was purchased or go directly to the manufacturer

**Manufacturer's Address:**

CynkoMet Sp. z o.o.  
ul. Fabryczna 7 W  
16-020 Czarna Białostocka  
tel. . (085) 710 24 56

INSTRUCTIONS FOR USE AND SERVICE CONSTITUTES BASIC  
EQUIPMENT OF THE MACHINE!

The machine is designed in accordance with the applicable standards, documents and legal regulations currently in force.

**DETERMINATION OF DIRECTIONS IN THE MANUAL**

Left side - side to the left hand of the observer facing in the direction of travel of the machine forward.

Right side - the right-hand side of the observer facing in the direction of travel of the machine forward.

# TRANSLATION OF DECLARATION OF CONFORMITY



16-020 Czarna Białostocka ul. Fabryczna 7 Polska

acting as the producer  
declare with full responsibility that the machine:

## THREE WAY TIPPER TRAILER

TYPE/ MODEL: T-149/1

YEAR OF PRODUCTION:

SERIAL NUMBER:

### BRIEF DESCRIPTION OF THE MACHINE AND ITS FUNCTIONS:

Two axle three-way tipper tractor trailer. The trailer chassis is made of: lower frame, drawbar and turntable frame which are steel constructions welded on a basis of steel sections and sheets. The primary carrying elements are two side members connected with crossbars. The trailer loading box is made of an upper frame with welded steel floor, side walls and side walls extensions. The trailer is designed to transport crops and other loose and volume materials within the limit of a farm and on public roads

### To which this declaration relates complies with the requirements:

- Directive 2006/42 / EC of the European Parliament and the Council of 17 May 2006 on machinery, and amending Directive 95/16 / EC (Dz. U.L157 from 09.06.2006, page,24-86)
- Regulations of the Minister of Economy of 21 October 2008. On essential requirements for machines (Dz. U. 2008 no 199 pos. 1228)

### For the conformity evaluation, the following harmonized standards have been used:

- PN-EN ISO 12100:2012 Safety of machinery - General principles for design-Risk Assessment and reducing the risk
- PN-EN 1853+A1 Agricultural Machinery – Tipping Trailers – Safety requirements year 2009
- PN-EN ISO 4254-1: 2016-02 Farm Equipment - Safety - Part 1: General requirements
- PN-EN ISO 13857:2010 Safety of machinery - Safety distances preventing reaching the upper and lower limbs to dangerous areas
- PN-ISO 11684:1998P Tractors, machinery for agriculture and forestry, moto tools- Safety signs and pictograms of threats - General provisions

The person authorized to prepare technical documentation:

Head of Constructors and Technologists Address:

Fabryczna 7,16-020 Czarna Białostocka , Poland

THE DECLARATION LOSES ITS VALIDITY, IF THE MACHINE IS CHANGED OR REBUILT WITHOUT CONSENT OF THE PRODUCER.

## Table of contents

<b>1. Introduction .....</b>	<b>8</b>
1.1 Identification of the machine .....	9
<b>2. Purpose of the trailer .....</b>	<b>11</b>
<b>3. Safety in use.....</b>	<b>14</b>
3.1 General safety and accident prevention regulations 14	
3.2 Attaching and detaching the machine to the tractor .....	16
3.3 Attaching and detaching the second trailer .....	17
3.4 Tires .....	17
3.5 The pneumatic and hydraulic system.....	18
3.6 Maintenance.....	19
3.7 The principles of movement on public roads. ....	20
3.8 Description of residual risk. ....	24
3.9 Assessment of residual risk.....	25
3.10 Information and warning stickers.....	26
<b>4. Information regarding use.....</b>	<b>30</b>
4.1 Technical characteristics.....	30
4.2 Description of construction and operation.....	31
4.2.1 Chassis.....	31

4.2.2 Loading crate .....	34
4.2.3 The hydraulic installation of the lift .....	36
4.2.4 Brake system .....	38
4.2.5 Electrical installation, lighting and signaling ....	41
4.3 Rules of proper use of trailers. ....	44
4.3.1 Preparation before running for the first time. ....	44
4.3.1.1 Control of the trailer after delivery .....	44
4.3.1.2 Preparation of the trailer for the first connection.....	45
4.3.2 Preparation for work. ....	47
4.3.3 Connecting and disconnecting with the tractor. .....	47
4.3.4 Connecting and disconnecting the second trailer. ....	50
4.3.5 Loading the crate. ....	51
4.3.6 Load transport .....	60
4.3.6 Crate unloading .....	62
<b>5. Equipment and accessories .....</b>	<b>68</b>
<b>6. Technical Support.....</b>	<b>70</b>
6.1 Regulation of driving wheel bearings backlash....	73
6.2 Brakes regulation.....	75

---

6.3 Brakes regulation.....	77
6.4 Hydraulic installation maintenance.....	79
6.5 Handling the spring leaf system. ....	80
6.6 Handling electrical equipment. ....	81
6.7 Lubrication. ....	81
6.8 Storage and maintenance. ....	84
6.9 Troubleshooting.....	85
<b>7. Transport.....</b>	<b>88</b>
<b>8. Trailer cassation.....</b>	<b>91</b>
<b>9. Guarantee .....</b>	<b>92</b>
<b>10. Environmental hazard .....</b>	<b>93</b>
<b>95</b>	
<b>SPARE PARTS CATALOGUE.....</b>	<b>95</b>
<b>11. SPARE PARTS CATALOGUE.....</b>	<b>97</b>
11.1 Introduction.....	97
11.2How to use the catalogue. ....	97

# 1. Introduction

This manual describes the basic principles of safe use and operation of agricultural trailers, tippers.

	<p><b>CAUTION!</b></p> <p>Before using a trailer you should carefully read the contents of the manual.</p> <p>Before running a trailer, you must test it for safe exploitation.</p>
---	---

If the information contained herein will prove to be not fully understood, ask the manufacturer or the sales point where it was purchased for help.

Particularly important information and recommendations, the observance of which is absolutely necessary in the text are highlighted in bold or preceded by the word „ **CAUTION!**”.

Information, descriptions of danger and precautions as well as commands and orders "related to the safety of use are

highlighted in the manual with a sign  and also mentioned in the chapter "SAFETY OF USE".



## 1.1 Identification of the machine

The trailer is marked with the plate (1) and a serial number (2). The serial number is located on the front beam of the lower frame, and the nameplate is located on the front beam of the upper frame - figure 1.

When buying the trailer, check the compatibility of serial numbers on the machine with the number written in *the WARRANTY CARD* , in the sales documents and in the *MANUAL*.

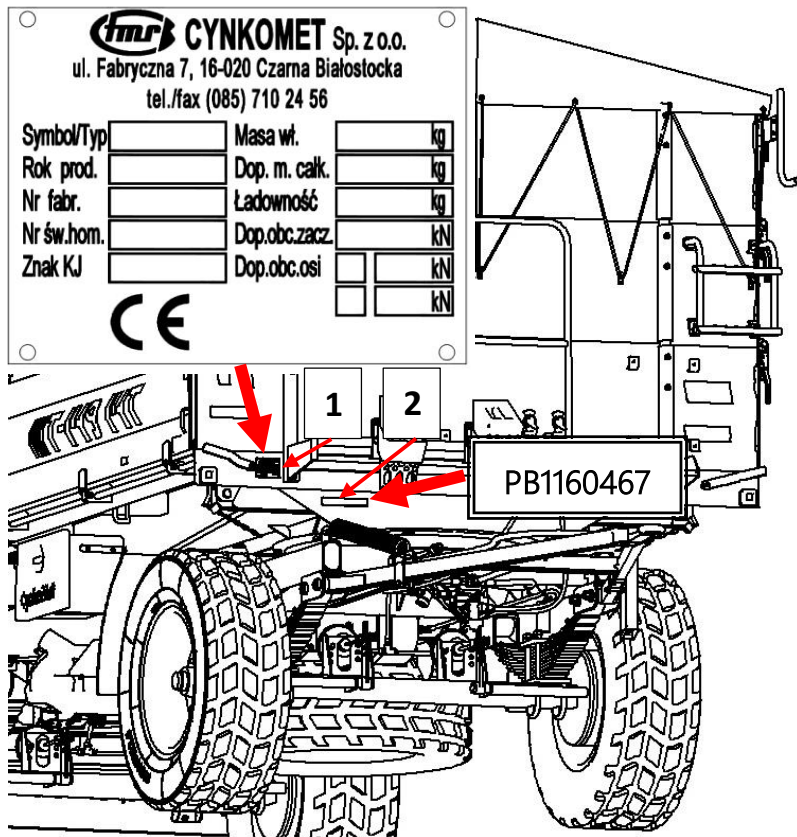

Figure 1. Location of the nameplate and issue of the serial number

1 - nameplate, 2 - serial number

## 2. Purpose of the trailer

The trailer is designed to transport crops and other loose and volume materials within the limit of a farm and on public roads

The braking, lighting and signaling systems meet the requirements of road traffic regulations.

The trailer is adapted to cooperation with agricultural tractors fitted with an external hydraulic system and upper trailer hitch. The rear trailer hitch is only used to connect the trailer biaxial. Failure to follow the transport and loading of goods specifications described by the Manufacturer and the rules on road transport in force in the country in which the trailer is utilized, will void the warranty service and is regarded as misuse of the machine.

The trailer **IS NOT ADAPTED** and cannot be used to transport people and / or animals.

 <p><b>CAUTION!</b></p>	<p><b>CAUTION!</b></p> <p>The trailer must not be used for any other purpose, and in particular:</p> <ul style="list-style-type: none"><li>• for transporting people and animals,</li><li>• for transporting bulk hazardous toxic materials when there is a possibility of causing environmental contamination,</li><li>• to transport machinery and equipment, whose center of gravity affects the stability of the trailer,</li><li>• to carry loads, machines, etc. that affect the unequal load or overload of axles and suspension components,</li><li>• to carry loads not secured, which - while driving - can change its position on the loading platform.</li></ul>
--	--

- Use in accordance with the product's destination also includes all activities related to correct and safe operation and maintenance of the machine. Therefore, the user is obliged to:
- read the content of the *MANUAL* of the trailer and the *WARRANTY CARD* and adhere to the recommendations contained in these elaborations,
  - comply with the established maintenance plans and regulations,
  - comply with general safety regulations while working
  - Prevent accidents,
  - comply with the road traffic regulations and transport regulations in force in the country in which the trailer is operated,

- read the instructions for operating the tractor and comply with its recommendations,

The trailer may only be used by persons who:

- are familiar with the contents of publications and documents attached to the trailer and the contents of the agricultural tractor manual,
- have been trained in the use of the trailer and safety at work
- have the required authorization to drive and are familiar with the road traffic regulations and transport regulations.

## 3. Safety in use

### 3.1 General safety and accident prevention regulations

- Before using a trailer, user should carefully read the instructions completely. During operation, observe all instructions contained in the manual.
- Before running a trailer, it must be checked for operational safety.
- Entering the trailer is possible only during absolute motionlessness of the machine and when the engine is switched off.
- The trailer should be combined with tractors recommended by the manufacturer.
- Pay attention to the warnings in places of crushing and shearing when starting the machine.
- During transport, check the condition of preheat of the tires, brake drums and wheel bearings. In the case of detecting an excessively heating element, stop the machine from operating until determining the cause and rectifying the fault.

 <p><b>CAUTION!</b></p>	<p><b>CAUTION!</b></p> <p>Before driving with a trailer in a place where there are flammable materials you should imperatively check the status of the heating elements of the trailer, especially the brake drums and wheel bearings, due to the risk of fire.</p>
--	---

- The speed of driving must always be adapted to the

environmental conditions. Avoid travel on rough terrain and unexpected turns.

- When switching and disconnecting the machine from the tractor, you must be careful.
- Exceeding the permissible load can cause accidents on the road and damage to the machine.
- When cornering, you should take into account the inertia of the machine.
- Before you start, check if the trailer has any loose parts
- Within additional elements which are force operated (e.g. by hand), there are places of crushing and shearing.
- Malfunctioning of the trailer should be removed only when the engine of the tractor is off and the ignition key is pulled out
- No one can stay one between the tractor and the trailer before the vehicle is not be protected against self-running off through the parking brake (hand brake) and wedges under the wheels.
- The permissible transport speed 30 km / h cannot be exceeded.
- It is forbidden to transport people or animals on the trailer
- It is forbidden to enter the cargo box with an unsecured trailer.
- The machine is designed to work on slopes up to 8 °.
- Lifting the loading crate can only be done on level ground.
- When lifting the caret, keep a safe distance from overhead power lines.
- Disconnection of the trailer from the tractor is not allowed with the load crate lifted with the telescope cylinder.
- Modifications can be made only with the permission of the manufacturer. The basic condition for safety are original spare parts and components. Using other parts may result in exclusion of liability of the manufacturer for resulting

consequences.

- Careless operation and maintenance of the trailer can injure the operator or third parties and damage the tractor-trailer.
- It is forbidden to use the machine by persons not qualified to drive agricultural tractors, including children and persons under the influence of alcohol.
- It is forbidden to use the trailer contrary to its purposes. Staff operating the machine should be trained in the applicable health and safety regulations and the "Highway Code".
- Prior to each trailer's use check its technical condition, especially the condition of the coupling system, drive system, brakes and signaling lights.
- The machine is marked with information and warning inscriptions in the form of stickers as specified in Table 1. The user is obliged to constantly take care of the readability of signs and warning symbols on the machine. In the event of damage or destruction replace them with new ones.
- Labels with inscriptions and symbols are available from the manufacturer.

### **3.2 Attaching and detaching the machine to the tractor**

- Before attaching a trailer, make sure that the tractor and trailer are technically efficient.
- While connecting the trailer, use only the upper transport hitch of the tractor. After completion of the machine coupling, check the security of the hitch. Read the whole manual for the tractor's use. If the tractor is equipped with an automatic hitch, make sure the coupling operation has been completed correctly.



- Be very careful when you connect the machine.
- When connecting, nobody may stay between the trailer and the tractor.
- Disconnecting the trailer from the tractor is prohibited if the load crate is raised.
- Coupling and uncoupling the trailer may only take place when the machine is immobilized with the parking brake.

### **3.3 Attaching and detaching the second trailer**

- Before connecting the machine, make sure that the oil in both trailers may be mixed.
- Only two-axle trailers can be connected to the trailer.
- Before attaching a trailer, make sure that both machines are technically efficient.
- Be very careful when you connect the machine.
- In the course of coupling no one is allowed to stand between trailers. The person who helps to aggregate the machine should stand in such a place (outside the danger zone) to be visible all the time to the operator of the tractor.
- After completion of the coupling of the trailer, check the safety of the hitch.
- Disconnecting the second trailer is prohibited if the load crate is raised

### **3.4 Tires**

- When working with the tires, secure the trailer, in case of self-launching of movement, using the parking brake and wheel chocks.

- Repair work on the tires and wheels should be performed by trained personnel and using appropriate tools.
- After each installation of a wheel, tighten the nuts after the first 10 working hours, then every 50 working hours to check their screwing.
- The air pressure is to be checked regularly. Observe the recommended air pressure.
- Dismantling the wheels can be carried out only in the case when the trailer is not loaded.
- Avoid damaged road surface, quick and variable maneuvers and high speed during turns.
- Tire valves are to be protected with caps to prevent penetration of impurities.

### **3.5 The pneumatic and hydraulic system**

- The hydraulic and pneumatic installations during operation are under high pressure.
- Regularly check the technical condition of the connections and the hydraulic and pneumatic systems. Oil leaks and air leaks are unacceptable.
- The shut-off valve in the hydraulic system of the lift limits the angle of the load crate declination when tilting it sideways and backwards. The length of the cable controlling that valve is set by the manufacturer and may not be adjusted during use of the trailer.
- In case of failure of the hydraulic or pneumatic installation, the trailer should be out of operation until failure removal.
- When connecting the hydraulic hoses to the tractor, pay attention that the hydraulic system of the tractor and the

trailer are not under pressure. If necessary, reduce the residual pressure system.

- In the case of injury with a strong jet of hydraulic oil should, immediately consult a doctor. The hydraulic oil can penetrate the skin and cause an infection. If the oil gets into your eyes, rinse with plenty of water and consult a doctor.
- In the event of contact of oil with skin, wash the dirty spot with soap and water. Do not use organic solvents (petrol, kerosene).
- Use the hydraulic oil recommended by the Manufacturer.
- After replacing the hydraulic oil, the used oil must be disposed of Used oil or one that has lost its properties should be stored in its original containers or in substitute packages which are hydrocarbon-resistant. Replacement containers must be carefully described and stored properly.
- It is forbidden to store hydraulic oil in packaging designed for food storage.
- Rubber hydraulic couplings must be replaced every 4 years regardless of their technical condition. Replacing the coupling must comply with the technical requirements of the manufacturer.

### **3.6 Maintenance.**

- Repair, maintenance and cleaning jobs and the removal of function faults is to be performed with the engine of the tractor stopped and the ignition key taken out.
- During maintenance of the raised loading crate, it is advisable to protect it before falling with the help of the service support.
- During maintenance and repair jobs use appropriate tools and

protective clothing.

- Oils and lubricants are to be carefully removed. The used oil and grease is to be disposed of.
- Before electrical, welding and working works on the electrical system, separate the continuous supply of power to the electrical system of the tractor.
- Use the spare parts according to the catalog of spare parts.
- Modifications can be made only with the permission of the manufacturer. The basic condition for safety are original spare parts and components. Using other parts may result in exclusion of liability of the manufacturer for resulting consequences.

### **3.7 The principles of movement on public roads.**

- When driving on public roads you must adapt to the traffic regulations and transport regulations in force in the country in which the trailer is operated.
- Do not exceed the speed limit.
- Adapt the speed to the prevailing road conditions and the degree of loading of the trailer.
- While driving on public roads the trailer should be equipped with a certified or approved warning triangle. A triangular plate should be placed on the rear wall for slow-moving vehicles (1) as shown below (Fig. 2).

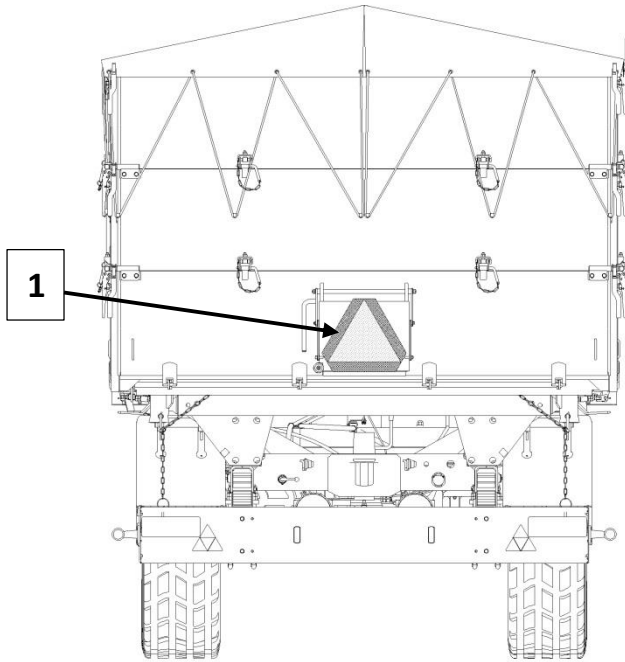

**Figure 2. The location of the placement of the plate distinguishing slow-moving vehicles.**

- The presence and transport of people in the trailer load crate is prohibited.
- Before driving, make sure that the trailer is properly connected to the tractor (in particular, check the safety pin hook).
- It is forbidden to park on the slopes with a loaded and unsecured machine. Securing is based on stopping with the service brake, parking brake and planting chocks under the wheels. The chocks (1) should be planted only under one wheel (2) (one front wheel and one on the back - Fig. 3). The chocks should not be placed under the front wheels.

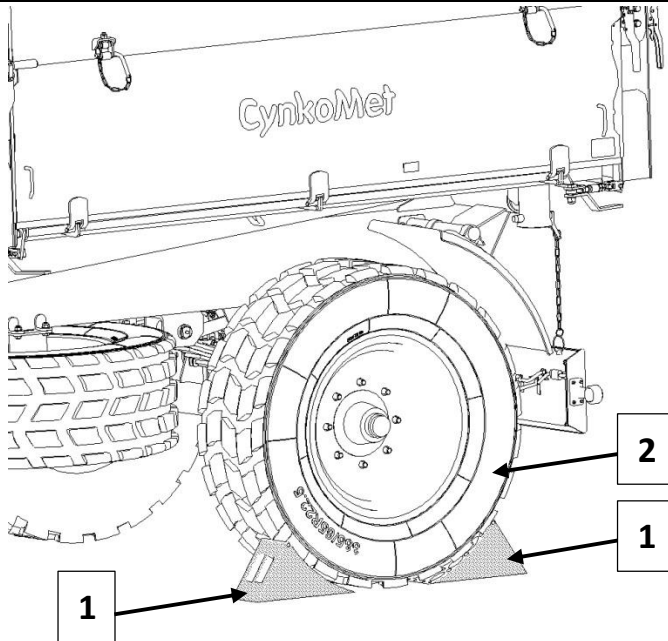

**Figure 3. The way of placing the chocks.**

- Before driving, check that the pins connecting the load crate with the lower frame and pins of the walls are protected against accidental falling out. Check the protection of the valve of the rear wall. Make sure that all walls and superstructures are properly closed. Check for proper mounting of the clamping cables.
- Prior to each trailer's use, check its technical condition, especially in terms of safety. In particular, check the technical condition of the coupling system, drive system, brakes and signaling lights and hydraulic, pneumatic and electrical connection elements.
- Before driving, check that the parking brake is released and the braking force regulator is set to the correct position

(concerns pneumatic systems with a manual, three-position regulation).

- The trailer is adapted for driving on slopes up to 8°. Moving the trailer through grounds with steeper slopes may cause the trailer to tip over as a result of loss of stability.
- Periodically drain the reservoir of air in the pneumatic system. During frosts, freezing water may cause damage to pneumatic system components.
- The cargo protruding beyond the outline of the trailer should be marked in accordance with the rules of the traffic.
- It is prohibited to exceed the admissible trailer load. Exceeding the carrying capacity may lead to equipment damage, loss of stability while driving, scattering of the load and cause a hazard while driving. The brake system of the machine has been adapted to the total weight of the trailer, which if exceeded will result in a drastic reduction in the effectiveness of the brake.
- The load on the trailer should be distributed evenly and must not impede driving the set. The load must be secured so as not to have the ability to move or fall over.
- When reversing, it is recommended to use the assistance of another person. During maneuvering, the person helping must keep a safe distance from the danger zones and at all times be visible to the operator of the tractor.
- If during reversing we are not using the help of a second person, before commencing the maneuver, make sure that nobody is in the danger zone. Before the start of the maneuver, use a sound signal.

### 3.8 Description of residual risk.

Although the "CYNKOMET" Czarna Białostocka company takes responsibility for the design and construction in order to eliminate the danger, and made every effort to eliminate the risk of an accident, some elements of risk during operation of the trailer are unavoidable. The residual risk stems from the wrong behavior of the machine operator.

The greatest danger occurs when you do the following:

- use the trailer for purposes other than those described in the manual,
- stay between the trailer and the tractor when the engine is running,
- operate the machine by unauthorized persons or under the influence of alcohol or other drugs,
- stay on the machine during operation,
- clean the machine during operation,
- not keep a safe distance during loading or unloading of the trailers,
- Introduce structural changes without the consent of the Manufacturer,
- clean, carry out maintenance and technical checks of the trailer,
- the presence of people or animals in areas invisible from the driver's position.

When presenting the residual risk, the trailer is treated as a machine, which until the start of production was designed and manufactured according to the current "state of the art".



### 3.9 Assessment of residual risk

When observing such recommendations as:

- carefully reading the user manual.
- prohibition of placing your hands in inaccessible and forbidden places,
- prohibition on being on the machine during operation,
- maintenance and repair of machines only by trained personnel,
- operating the machine by persons who have been previously trained and familiar with the instructions,
- working with the components and elements with sharp edges you must wear suitable protective clothing (gloves, boots, etc.)
- securing the machine against the access of children,
- reasonable use of the observations and recommendations contained in the operating instructions,
- keeping a safe distance from forbidden or dangerous places during unloading, loading and coupling trailers,
- performing maintenance and repair jobs in accordance with the security service rules,
- prohibition on being on the machine during driving, loading or unloading.

can be eliminated residual risk with the use of the machine without risk to humans and the environment.



**CAUTION!**



#### **CAUTION!**

There is residual risk in the event of failure to comply with the set-out recommendations and guidelines.

### 3.10 Information and warning stickers.

The trailer is marked with information and warning labels listed in table 1. The user of the machine is obliged to take care of the readability of the subtitles, warning symbols and information placed on the trailer throughout the whole period of its use. In the case of destruction, replace them with new ones. Labels with inscriptions and symbols are available from the manufacturer or the place where the machine was purchased. New components, replaced during repairs must be re-marked with appropriate safety signs. When cleaning the trailer, do not use solvents that can damage the coating of labels and do not direct a strong stream of water.

Table 1. Information and warning stickers.

No.	The symbol (sign) of safety or the content of the inscription	Meaning of the symbol (sign)	The placement on the machine
1.		Caution Before starting work, please read the User's Manual.	Front wall
2.		Caution Turn off the engine and remove the key before starting maintenance or repair	Front wall
3.	The inscription "Do not make service and repair work under loaded or raised and unsupported loading crate."	-	Front wall
4.	The inscription "Before unloading the trailer, unlock two pins connecting the gearbox to the frame on the opposite side of the dump. Raised trailer, keep a safe distance. "	-	Front wall
5.	The inscription "Connecting only with the upper transport	-	Front wall

	hitch of the tractor."		
6.	„1“, „2“ - applies to hydraulic circuits I and II of the trailer	The position of the valve controlling the operation of the hydraulic installation (trailer 1 or 2).	Shut-off valve
7.	<b>400 kPa</b>	Pressure in the tires <sup>(1)</sup>	On the side walls above the wheels
8.		Do not reach into the area of crushing, if the elements may be Moving.	On the side walls, the back one and the dump window.
9.	<b>CynkoMet</b>		The right-side wall, left side wall
10.	<b>    T-149 14T</b>		The right-side wall, left side wall

<sup>(1)</sup> – pressure dependent on the used tire

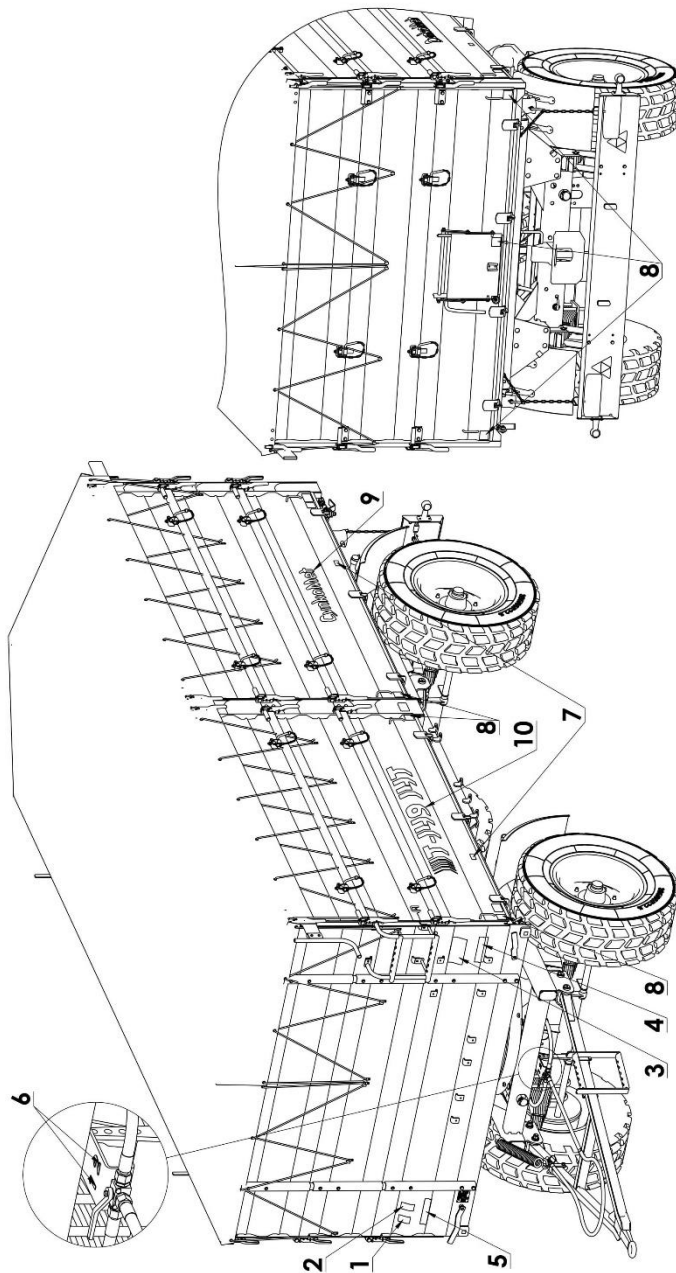

Figure 4. Distribution of stickers.

## 4. Information regarding use

### 4.1 Technical characteristics.

**Table 2. Basic technical specifications of the trailer.**

NO.	Content	J.m.	T-149/1
1.	Total length	mm	7280
2.	Total width	mm	2550
3.	Total height	mm	2340 <sup>(2)</sup> -3150 <sup>(3)</sup>
4.	Track of wheels	mm	1800
5.	Dimensions of the loading crate: <ul style="list-style-type: none"> <li>• Length</li> <li>• width</li> <li>• height</li> </ul>	mm	5130 2420 1000 <sup>(2)</sup> -1500 <sup>(4)</sup>
6.	cargo capacity	m <sup>3</sup>	12.3 <sup>(2)</sup> /18.5 <sup>(4)</sup>
7.	Loading surface	m <sup>2</sup>	12.3
8.	Height of the loading surface	mm	1340
9.	The ground clearance of the vehicle	mm	420
10.	Vehicle weight	kg	4200-4480
11.	Allowed payload of the vehicle	kg	13800-13520 <sup>(5)</sup>
12.	The angle of inclination of the box: <ul style="list-style-type: none"> <li>• from side to side</li> <li>• Backwards</li> </ul>	(°) (°)	50 50
13.	Wheelbase	mm	3500mm
14.	Tire size		385/65 R22.5
14.1	Tires Speed Index		F (80km/h)
14.2	Tires Load Index		160 (4500kg)
14.3	The maximum tire pressure	bar/kPa	9 / 900
15.	Rated voltage	V	12
16.	Permissible design speed	km/h	40 <sup>(6)</sup>
17.	Power requirement	kW/KM	74 / 100
18.	The level emitted of noise	dB	Below 70

<sup>(2)</sup> – without mounted center extensions

<sup>(3)</sup> – with fitted middle extensions, frame and tarpaulin

<sup>(4)</sup> – without mounted center extensions

<sup>(5)</sup> – capacity depends on the equipment of the trailer

<sup>(6)</sup> – The permitted speed limit of the trailer moving on public roads in Poland is 30 km / h (according to the Law dated 20 June 1997, "the Road Traffic Law", art. 20). In countries where the trailer is operated, observe the restrictions associated with the relevant national law on road traffic.

## 4.2 Description of construction and operation.

### 4.2.1 Chassis

The chassis of the trailer consists of the following parts shown in Fig. 5.

The lower frame (1), shaft (3) and the turntable frame (2) are welded constructions of steel and sheet metal. The basic carrying elements are two stringers connected to each other via crossbars. In the corners of the frame there are pivots (11) for depositing the upper frame; whereas in the central part there is a socket (7) for depositing the hydraulic cylinder. In front of the chassis there is a pull-torsion system of the trailer, and it consists of: a front axis (1), turntable (8), the turntable frame (2), spring (6) and the shaft (3). In the rear of the chassis, there is the rear driving axle suspension (1) placed and elements of the rear lighting unit (10). Over the lighting beam, the rear hitch is rotated (12). The hook is designed to aggregate a second machine (biaxial).

Driving axles are made of square bars ending with pivots on which on the tapered roller bearings, wheel hubs are mounted (13). The axles are equipped with shoe brakes channeled with mechanical cam expanders. The trailer suspension consists of four steel leaf springs attached to the swivel frame and the lower frame by pins and slides. The wheel sets are attached to the springs with glomerular bolts.

To the frame of the turntable (2) a drawbar is mounted (3) with a tie rod  $\varnothing 50$  mm. The drawbar height can be adjusted by changing the position of the bracket of the shaft spring connected with a shaft spring (9).

Optionally, the trailer can be fitted with a spare wheel with a hanger (14). The spare wheel is mounted under the lower frame on the left side of the trailer.



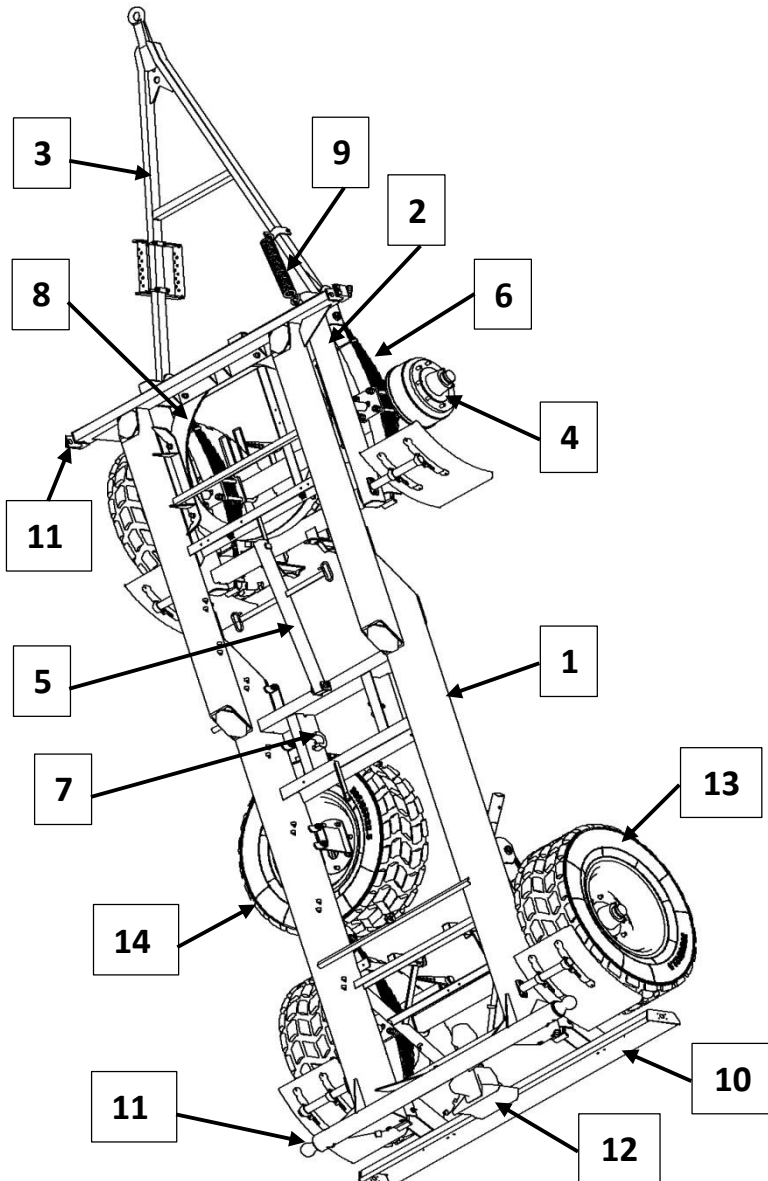

**Figure 5. Trailer chassis.**

1 – bottom frame, 2 – frame turntable, 3 – shaft, 4 – driving axle, 5 – crate support, 6 – spring, 7 – suspension socket of the hydraulic cylinder, 8 - turntable, 9 – drawbar spring, 10 – lighting beam, 11 – pin, 12 - rear hook, 13 – driving wheels, 14 – spare wheel with a hanger

## 4.2.2 Loading crate

The loading crate of the trailer (fig. 6) is formed by the upper frame (1) with a welded steel floor, A, B, C walls and single or double wall extensions D, E, F.

The upper frame is mounted on the pins of the lower frame (p.11 fig.5) in swiveling sockets secured with bolts, which are rotation points when tipping the load crate.

The side walls (A) and side extensions (D) are divided in half of their length into two parts - segments. Each segment has a separate set of locks, which allows opening and closing of individual parts of walls and the extensions independently of each other and in any order. Such a construction solution increases the functionality of the trailer and makes it easier to service.

The locks of the walls and extensions, as well as the bolt of the dump window are protected against spontaneous, undesirable opening.

The walls and side extensions and are connected together by means of clamping cables (2).

Entrance ladders are fixed to the walls and the front extension. From the inside of the front extension, attached is an extra step facilitating entry into the loading crate.

In addition, the trailer T-149 can be fitted with roll-up tarpaulin with the frame and a front platform.

In order to allow a more precise unloading of materials in powder form, a dump window is provided in the rear wall (Fig.7).

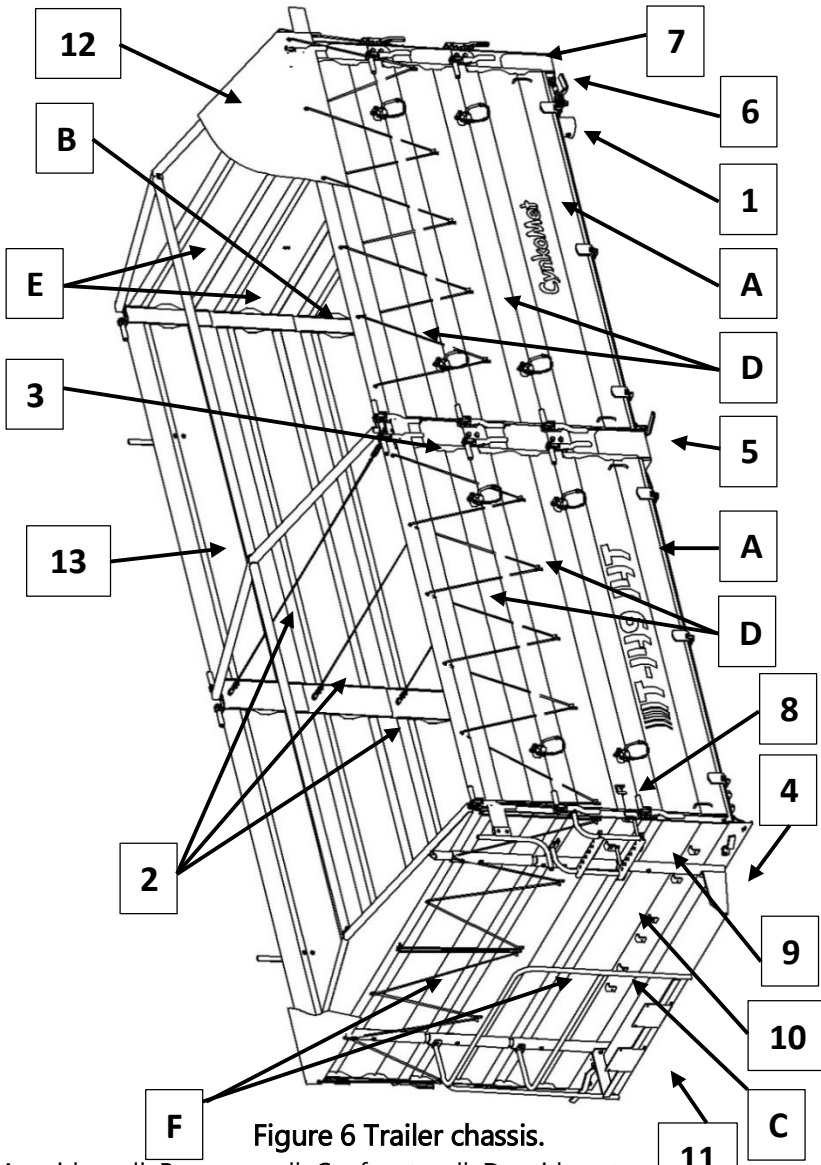

**Figure 6 Trailer chassis.**

A – side wall, B – rear wall, C – front wall, D – side extension, E – rear extension, F – from extension, 1 – bottom frame, 2 - fastening cable, 3 – center post, 4 – lever of the lower bolts of the front wall segment, 5 - lever of the lower bolts of the rear wall segment, 6 - lever of the lower bolts of the rear wall, 7 – rear post, 8 – hinge, 9 – wall lock, 10 – ladder, 11 - front platform, 12 – tarpaulin, 13 – tarpaulin frame

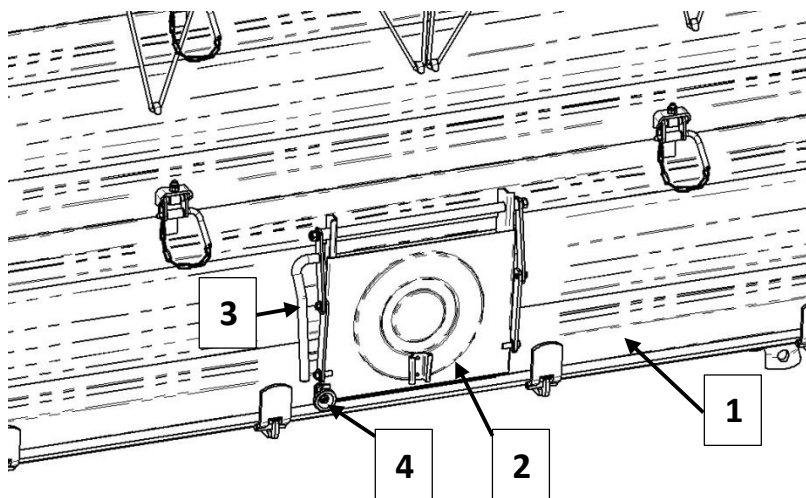

Figure 7. Dump window.

1 - rear wall, 2 - window dump, 3 - lever, 4 - locking screw

### 4.2.3 The hydraulic installation of the lift

Hydraulic tipping mechanism is designed for automated unloading of the trailer through tilting the load crate backwards or sideways. The hydraulic system of the dumping mechanism is supplied with oil from the tractor's hydraulic system. To control the lifting of the loading crate, the oil distributor of the external hydraulic tractor is used

The hydraulic system consists of two independent circuits, namely:

- Circuit I - used to power the telescoping cylinder that raises the cargo box;
- Circuit II - is used to power the hydraulic system of the second trailer, in the case of a merger of two tractor trailers simultaneously.

To turn these circuits, a three-way valve (2) is used. The

lever of this valve can occupy the following positions:

- position "1" - open circuit of the trailer tipping
- location "2" - open circuit of the second trailer tipping

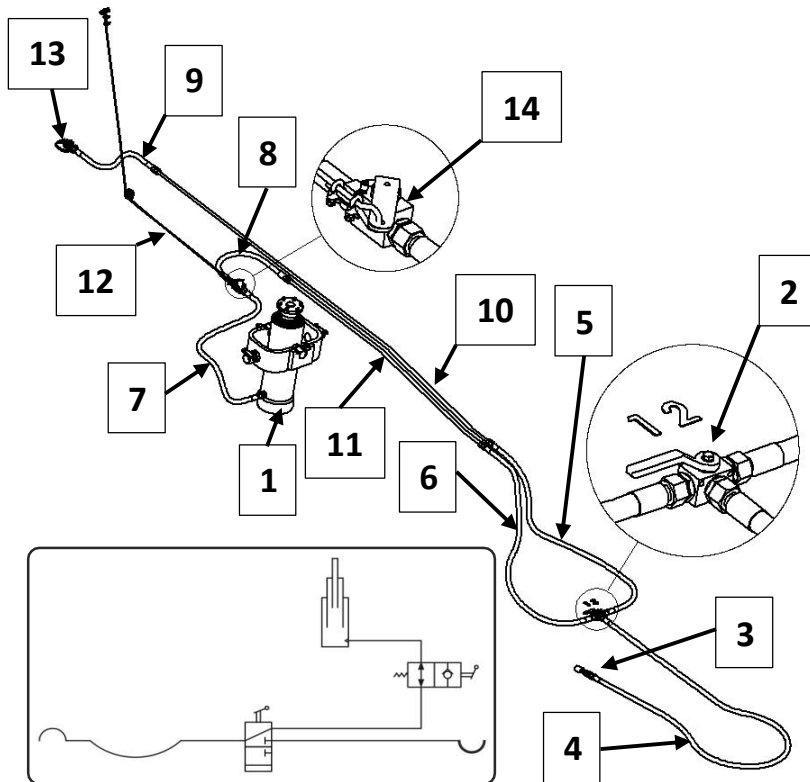

Figure 8. Construction and diagram of the hydraulic tipping installation

- 1 - hydraulic cylinder; 2 - three-way valve; 3 - valve connector plug; 4, 5, 6, 7, 8, 9 - flexible hydraulic hoses; 10, 11 - rigid hydraulic hoses; 12 - cable controlling the reciprocal valve; 13 - the socket of the valve connector of second trailer; 14 - shut-off reciprocal valve.



**CAUTION!**

**CAUTION!**

The factory hydraulic system of the trailer is filled with oil **Agrol U**.

 <p><b>CAUTION!</b></p>	<p><b>CAUTION!</b></p> <p>The reciprocal shut-off valve (p. 14 Figure 7) limits the angle of the declension of the load box when tilting it backwards and sideways. The length of the cable controlling that valve is adjusted by the manufacturer and should not be adjusted during operation of the trailer.</p>
--	--

## 4.2.4 Brake system

The trailer is equipped with a braking system comprising of:

- a pneumatically controlled brake, acting on four wheels of the rear and the front axle,
- a parking brake actuated manually by means of a crank mechanism on the side of the trailer, acting on the rear wheels.

The pneumatic brake is activated from the workplace of the tractor driver by pressing the brake pedal of the tractor. The construction of this brake provides automatic inhibition of the four driving wheels of the trailer with an unexpected disconnection of the pneumatic trailer and tractor. The used valve has a brake release system used in the case when the trailer is disconnected from the tractor (fig. 10).

The braking force 3 regulator located in the suspension system (fig.9) (fig.10) is controlled manually. Depending on the load of the trailer with cargo, the control lever must be set in one of three positions:

- position "0" - for an unladen trailer,
- position "1/2" - for the trailer partially loaded,
- Position "1" - for the trailer fully loaded.

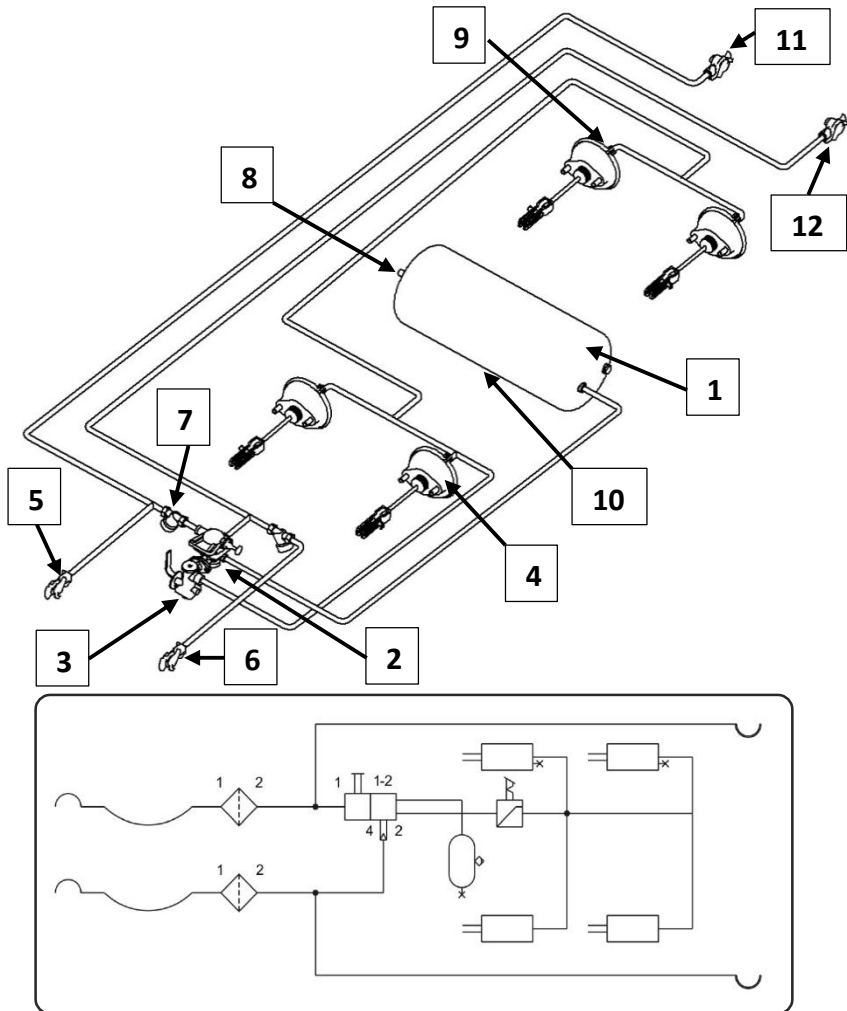

**Fig. 9. A diagram of the pneumatic two-wire braking installation**

1 – air reservoir, 2 - control valve, 3 - braking force regulator,  
 4 - pneumatic actuator, 5 - cables connectors (red), 6 - cables  
 connectors (yellow), 7 - air filters, 8 - control connector of the air  
 reservoir, 9 - control connector of the pneumatic cylinder, 10 - drain  
 valve, 11 - socket (red), 12 - socket (yellow)

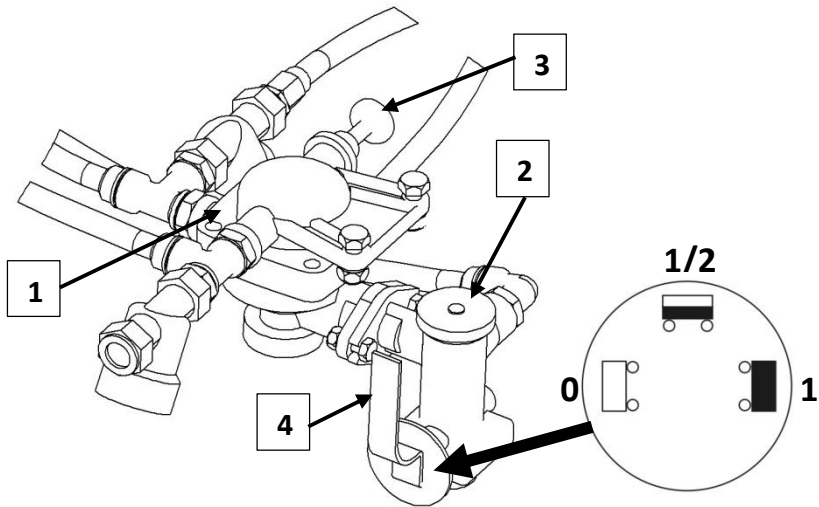

**Fig. 10. Pneumatic braking force regulator.**

1 – control valve, 2 - braking force regulator, 3 - a button releasing the brake of the trailer at standstill, 4 - the lever of the regulator's work selection, 0 - „UNLADEN” position, 1/2 - „HALF LOADED” position , 1 - „FULL LOAD” position

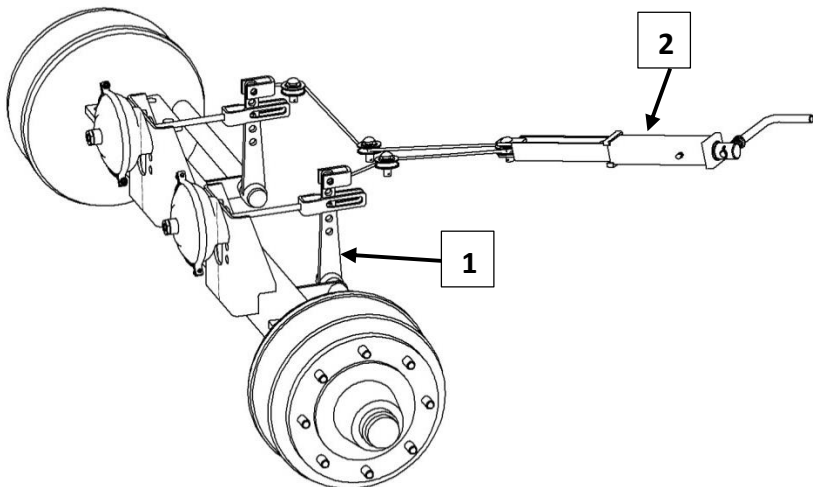

**Fig. 11. Parking brake**

(1) the spreader lever, (2) crank mechanism, (3) string, (4) pulley



The parking brake is used to immobilize the trailer when stationary. The brake crank mechanism 2 (fig.11), welded to the right side of the side-member of the lower frame. Steel cable 3, led by the rollers 4, is connected to the levers of the rear spreader driving axle (1) with the crank mechanism. Tightening the string (rotation of the crank mechanism in the direction of the clock's rotation) causes a shift of the lever spreader that, when parting the brake linkage, immobilize the trailer.

## 4.2.5 Electrical installation, lighting and signaling

Electrical installation of the trailer (fig. 12) is designed to be powered from a DC voltage source of 12V. Joining the electrical installation of the trailer of the tractor should be made with a suitable connecting line.

The socket 7 of the connector (fig. 13) is used to connect the electrical installation of the second trailer.

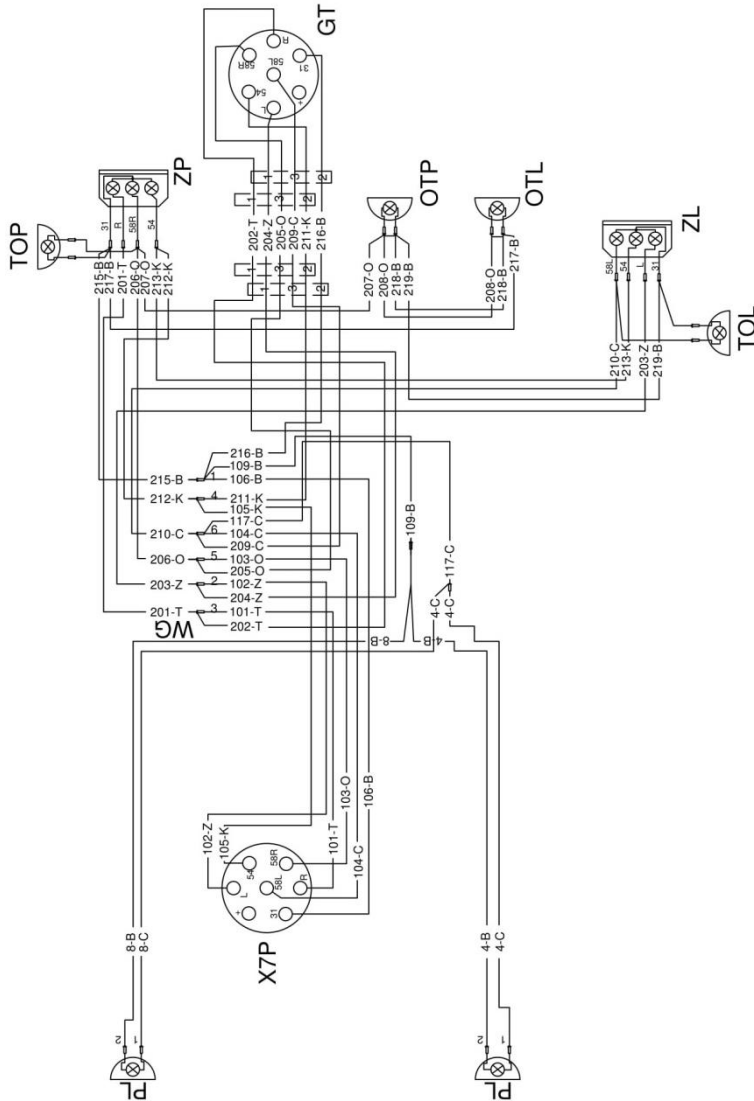

**Fig. 12. Wiring diagram of the trailer.**

(PL) front clearance lamp, (X7P) front seven-slot socket, (GT) rear seven-slot socket, (TOP, TOL) Rear clearance lamp, (OTP, OTL) lighting lamp of the license plate, (ZP) rear right assembly lamp, (ZL) rear left assembly lamp

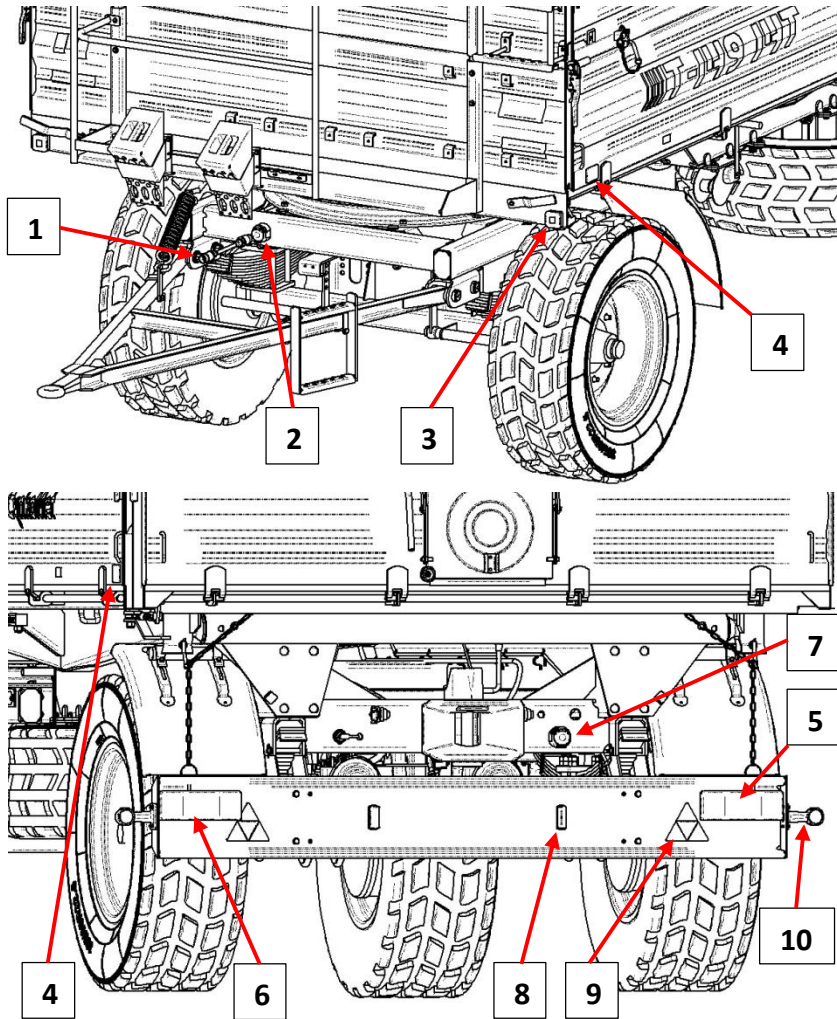

**Fig. 13. Lighting and signaling diagram**

1- complete connecting cable; 2 - connector socket - outlet; 3 - front position lamp with a reflector; 4 - reflective yellow device; 5 - rear right multifunction lamp; 6 - rear left multifunction lamp; 7 - the socket of the connector for connecting the second trailer; 8 - lamp for lighting the license plate; 9 - red triangle reflective device; 10 - rear assembly light

## 4.3 Rules of proper use of trailers.

### 4.3.1 Preparation before running for the first time.

#### 4.3.1.1 Control of the trailer after delivery

The manufacturer guarantees that the trailer is fully operational and has been checked according to quality control procedures and is approved for use. However, this does not relieve the user from the obligation of checking the vehicle after delivery and before first use. The machine is provided to the user in a fully assembled state.

Before starting work, the operator of the trailer must inspect the technical condition of the trailer and prepare it for the first run. Please refer to this manual attached to the trailer and follow the recommendations contained in it, take a look at the design and understand the principle of operation of the machine.

	<p><b>CAUTION!</b></p> <p>Before connecting and before starting the trailer, read this manual and follow the instructions contained therein.</p>
--	--

Visual inspection:

- Check the completion of the machine (standard and optional equipment).
- Check the condition of the anti-corrosion coatings.
- Perform a visual inspection of the individual components of the trailer for mechanical damage resulting inter alia due to improper transport of machines (dents, piercing, bending or broken components).

- Check the condition of tires of the driving wheels and the air pressure in the tires.
- Inspect the technical state of the flexible hydraulic hoses.
- Check the technical condition of pneumatic cables.
- Make sure that there are no leaks of hydraulic oil.
- Check the electric lamps of lighting.

#### **4.3.1.2 Preparation of the trailer for the first connection.**

##### Preparation

- Check all lubrication points of the trailer, if necessary, lubricate the machine.
- Check for proper tightening of nuts fixing the driving wheels.
- Dehydrate the air tank in the brake installation.
- Make sure that the pneumatic, hydraulic and electrical connections in the agricultural tractor comply with the requirements, otherwise do not connect the trailer.
- Adjust the height of the shaft location in the trailer or the position of the upper transport hitch on the tractor.

##### Trial passage

If all the above steps have been performed and the technical condition of the trailer does not raise any objections connect the machine to the tractor. Start the tractor, inspect the individual systems and carry out a test run of the trailer and make a road test with no load (no loaded create). It is recommended to carry out an inspection by two people, one of them should reside in the operator's cab of the tractor. The test run should be carried out in the order shown below.

- Connect the trailer to an appropriate hitch in the agricultural tractor.

- Connect the wires of the braking, electrical and hydraulic systems.
- Running individual lights, check the correct operation of the electrical system.
- Switch the hydraulic installation tipping valve to position 1. Perform a test tipping of the load crate backwards and sideways.
- Moving from place, check the brake operation.
- Perform a test drive.

If during the test drive, you experience disturbing symptoms such as:

- noise and unnatural noises coming from moving parts rubbing against the trailer construction,
- leakage of hydraulic oil,
- pressure drop in the brake installation,
- incorrect operation of hydraulic and / or pneumatic actuators or other failures, diagnose the problem. If a fault cannot be removed or removing it will invalidate the warranty, please contact your dealer to resolve the problem or repair.

After completion of the test drive, check the tightness of the driving wheel nuts.

 <p><b>CAUTION!</b></p>	<p><b>CAUTION!</b></p> <p>Careless and improper use and operation of the trailer, and non-compliance with the recommendations contained in this manual is dangerous to your health. It is forbidden to use the trailer by persons not qualified to drive agricultural tractors, including children and drunken persons. Failure to observe the rules of safe use poses a threat to the health of the operator or bystanders.</p>
--	--

### 4.3.2 Preparation for work.

In preparation for work, the following should be checked:

- the wear of the tires and driving wheels,
- Air pressure in the tires,
- springs condition, and in particular the completeness of the feathers
- tightening the nuts fixing the discs of the driving wheels to wheel hubs and the condition of other screw connections.

In addition, after combining the machine with the tractor check:

- the efficiency of the electrical system and lighting system and trailer signaling,
- the effectiveness of the brake system,
- the correct operation of the hydraulic discharge mechanism through trial tilting of the load crate backwards or sideways.

### 4.3.3 Connecting and disconnecting with the tractor.

The trailer can be connected to the tractor, if all connections (electrical, pneumatic, hydraulic), and a hook in the agricultural tractor shall comply with the requirements of the manufacturer of the trailer.

In order to connect the trailer to the tractor, perform the following steps:

- Prior to coupling with tractor, check if the trailer is braked with the parking brake.



**CAUTION!**

### **CAUTION!**

At the time of the coupling, unauthorized people cannot be between the trailer and the tractor. The operator of the tractor, when connecting the machine should be particularly careful when working and make sure that in the course of coupling, other people are not in the danger zone.

When connecting the hydraulic hoses to the tractor, pay attention that the hydraulic system of the tractor and the trailer are not under pressure.

When coupling ensure adequate visibility.

Connecting the trailer with a hitch other than a transport hitch is unacceptable because it threatens the safety of road traffic

After completion of the machine coupling, check the security of the hitch.

- Set the drawbar hitch anchorage on the height of the transport hitch of the tractor (this can be achieved by adjusting the drawbar spring tension).
- Reversing the tractor, connect the drawbar end with the upper transport hitch of the tractor (if in the agricultural tractor, an automatic coupler is used, ensure that the aggregate operation has been completed correctly and the drawbar anchorage is secured).
- Stop the tractor engine.
- Install and secure the hitch pin against falling out.
- Connect with the electric, hydraulic and brake installation wiring with the trailer.
- Release the parking brake of the machine.



When connecting the braking system (two-wire pneumatic), the correct sequence of connecting cables is important. Be the first to connect the plug marked yellow to a yellow socket in the tractor, and then the plug marked in red to the red socket in the tractor. When you connect the second cable, the brake release system will switch to the normal mode of operation (disconnection or interruption of the air duct causes the trailer control valve to automatically switch to the position of actuating the brakes of the machine). The cables are marked with colored protective caps that identify the correct cable installation.

In order to disconnect the trailer from the tractor, perform the following steps:

- After stopping the tractor, brake the trailer with a parking brake.
- If a trailer with cargo is located on a steep slope or an elevation, it should be protected additionally against rolling by planting chocks under rear wheels.
- Disconnect the hydraulic, electrical and brake system cables of the trailer from the tractor
- When removing the pin, disconnect the drawbar from the transport hitch of the tractor and drive the tractor away.

	<p><b>CAUTION!</b></p> <p>Do not disconnect the trailer from the tractor when the loading crate is raised.</p> <p>When disconnecting the trailer from the tractor, keep caution.</p> <p>Provide yourself a good visibility. If it is not necessary, do not stay between the trailer and the tractor.</p> <p>Before disconnecting the hoses and rods, the cabin of the tractor must be closed to prevent it from unauthorized access. The tractor engine must be turned off.</p>
---	---

	<p><b>CAUTION!</b></p> <p>Pay attention to the compatibility of oils in the tractor hydraulic system and the hydraulic system of the trailer tipping.</p>
---	---

#### 4.3.4 Connecting and disconnecting the second trailer.

The second trailer can be connected only if it is a machine built on a chassis. Aggregating the second trailer with a kit requires experience in driving an agricultural tractor with a trailer. It is recommended to use the help of another person when coupling the second trailer, who will inform the operator of the tractor about the operation.

	<p><b>CAUTION!</b></p> <p>During linking, no one can stand between the trailers. The person who helps to aggregate the machine should stand outside the danger zone in the place where he will be visible all the time by the operator of the tractor.</p>
---	--

### Connecting the second trailer

- Tractor with the attached trailer first is to be set directly in front of the drawbar of another trailer.
- Immobilize the second trailer with a parking brake.
- Remove the swivel pin in the first trailer.
- Adjust the height of the drawbar of the second trailer in such a way as to allow to couple the machines.
- Reversing the tractor, drive the rear hook of the first trailer on the drawbar of the second trailer.
- Insert and secure the hook swivel
- Connect the pneumatic, hydraulic and electric hoses
- 

### Disconnect the second trailer

- Immobilize the tractor and trailer with a parking brake.
- Stop the tractor engine. Close the cab of the tractor protecting it from unauthorized access.
- Disconnect the pneumatic, hydraulic and electric hoses
- Unlock the swivel hook in the first trailer. Remove the swivel and drive the tractor away

## 4.3.5 Loading the crate.



**CAUTION!**

### **CAUTION!**

Loading of the crate can take place only when the trailer is connected to the tractor, set on level ground with the drawbar directed to drive forward and braked

You should aim for even load distribution in the loading crate. When loading, it is recommended to use a crane, loader or conveyor. Before loading, check that the locks, wall hinges and the dump window in the rear wall are closed. If the trailer

is equipped with tarpaulin, then before loading from "above" you should remove the tarpaulin and / or disassemble its frame.

When transporting materials exerting point pressure on the floor of the loading crate (e.g. large stones). before loading you should plant thick boards, thick plywood, etc. This will enable to achieve an even surface of the floor load and protect it from damage.

Lightweight, volumetric materials may be loaded above loading crate extensions, paying particular attention to the stability of the trailer and cargo, and protection against road littering. When transporting light materials, it is not allowed to mount cables connecting the wall. In other cases, springs must always be installed.

Regardless of the type of the load carried, the user is required to secure it in such a way that the load is not able to move freely and cause contamination of the road. If this is not possible, it is prohibited to transport such cargo.

Due to the varied density of the materials, the use of the total capacity of the container may result in exceeding the permissible load of the trailer.

The approximate permissible heights of loading layers of various materials and their bulk weights are given in Table 3.

Table 3

No.	Material type	Volume weight [kg / m <sup>3</sup> ]	Loading height* [m]	
			From	to
1	Root:			
2	raw potatoes	700 - 820	1.4	> 1.5
3	steamed mashed potatoes	850 - 950	1.2	1.3
4	dried potatoes	130 - 150	> 1.5	> 1.5
5	sugar beet - roots	560 - 720	> 1.5	> 1.5
6	fodder beet - roots	500 - 700	> 1.5	> 1.5
7	Organic fertilizers:			
8	Old manure	700 - 800	1.4	> 1.5
9	Long laying manure	800 - 900	1.2	1.4
10	Fresh manure	700 - 750	1.5	> 1.5
11	compost	950 – 1 100	1.0	1.2
12	dry peat	500 - 600	> 1.5	> 1.5
13	Mineral fertilizers:			
14	ammonium sulfate	800 - 850	1.3	1.4
15	potassium salt	1 100 – 1 200	0.9	1.0
16	superphosphate	850 – 1 440	0.8	1.3
17	basic phosphate	2 000 – 2 300	0.5	0.6

18	potassium sulphate	1 200 – 1 300	0.9	0.9
19	kainite	1,050 – 1 440	0.8	1.1
20	lime-rich ground fertilizer	1,250 - 1,300	0.9	0.9
21	Building Materials:			
22	cement	1 200 – 1 300	0.9	0.9
23	dry sand	1 350 – 1 650	0.7	0.8
24	wet sand	1 700 – 2 050	0.5	0.7
25	Full bricks	1 500 – 2 100	0.5	0.7
26	hollow bricks	1 000 – 1 200	0.9	1.1
27	stone	1 500 – 2 200	0.5	0.7
28	Soft wood	300 - 450	> 1.5	> 1.5
29	Hard timber	500 - 600	> 1.5	> 1.5
30	impregnated timber	600 - 800	1.4	> 1.5
31	steel structures	700 – 7 000	0.2	> 1.5
32	roasted ground lime	700 - 800	1.4	> 1.5
33	Slag	650 - 750	1.5	> 1.5
34	Gravel	1 600 – 1 800	0.6	0.7
35	plant litter and roughage:			
36	dry meadow hay for swath	10 - 18	> 1.5	> 1.5

37	hay wilted for swath	15 - 25	> 1.5	> 1.5
38	hay in a collective trailer (dry withered)	50 - 80	> 1.5	> 1.5
39	cut wilted hay	60 - 70	> 1.5	> 1.5
40	compressed dry hay	120 - 150	> 1.5	> 1.5
41	pressed wilted hay	200 - 290	> 1.5	> 1.5
42	stored dry hay	50 - 90	> 1.5	> 1.5
43	stored cut hay	90 - 150	> 1.5	> 1.5
44	clover (Lucerne), wilted for swath	20 - 25	> 1.5	> 1.5
45	clover (Lucerne), wilted cut on the trailer	110 - 160	> 1.5	> 1.5
46	clover (Lucerne), wilted on the collective trailer	60 - 100	> 1.5	> 1.5
47	stored dry clover	40 - 60	> 1.5	> 1.5
48	cut stored dry clover	80 - 140	> 1.5	> 1.5
49	dry straw in rolls	8 - 15	> 1.5	> 1.5
50	moist straw in rolls	15 - 20	> 1.5	> 1.5
51	damp straw cut on a volumetric trailer	50 - 80	> 1.5	> 1.5
52	dry straw cut on a volumetric trailer	20 - 40	> 1.5	> 1.5
53	dry straw on a collective trailer	50 - 90	> 1.5	> 1.5
54	Dry straw cut in a haystack	40 - 100	> 1.5	> 1.5
55	compressed straw (low degree of deformation)	80 - 90	> 1.5	> 1.5

56	compressed straw (high degree of deformation)	110 - 150	> 1.5	> 1.5
57	grain mass in rolls	20 - 25	> 1.5	> 1.5
58	grain mass cut on a volumetric trailer	35 - 75	> 1.5	> 1.5
59	grain mass on a collective trailer	60 - 100	> 1.5	> 1.5
60	green forage for swath	28 - 35	> 1.5	> 1.5
61	green forage cut on a volumetric trailer	150 - 400	> 1.5	> 1.5
62	green forage on a collective trailer	120 - 270	> 1.5	> 1.5
63	Fresh beet leaves	140 - 160	> 1.5	> 1.5
64	Freshly cut beet leaves	350 - 400	> 1.5	> 1.5
65	beet leaves on a collective trailer	180 - 250	> 1.5	> 1.5
66	Concentrated feed and compound feed:			
67	stored husks	200 - 225	> 1.5	> 1.5
68	oilcake	880 - 1 000	1.1	1.3
69	Ground fascine	170 - 185	> 1.5	> 1.5
70	Compound feed	450 - 650	> 1.5	> 1.5
71	Mineral feeding stuffs	1 100 - 1 300	0.9	1.0
72	Oat middling	380 - 410	> 1.5	> 1.5
73	wet beet skins	830 - 1,000	1.1	1.4
74	Extruded beet skins	750 - 800	1.4	1.5



75	Dry beet skins	350 - 400	> 1.5	> 1.5
76	bran	320 - 600	> 1.5	> 1.5
77	bone meal	700 - 1 000	1.1	> 1.5
78	Fodder salt	1 100 - 1 200	0.9	1.0
79	molasses	1 350 - 1 450	0.8	0.8
80	Silage (lower silo)	650 - 1 050	1.1	> 1.5
81	hay silage (tower silo)	550 - 750	1.5	> 1.5
82	Seeds:			
83	Vicia faba	750 - 850	1.3	1.5
84	charlock	600 - 700	> 1.5	> 1.5
85	peas	650 - 750	1.5	> 1.5
86	lentil	750 - 860	1.3	1.5
87	bean	780 - 870	1.3	1.4
88	barley	600 - 750	1.5	> 1.5
89	clover	700 - 800	1.4	> 1.5
90	grass	360 - 500	> 1.5	> 1.5
91	corn	700 - 850	1.3	> 1.5
92	wheat	720 - 830	1.4	> 1.5
93	rape	600 - 750	1.5	> 1.5

94	flax	640 - 750	1.5	> 1.5
95	lupine	700 - 800	1.4	> 1.5
96	oat	400 - 530	> 1.5	> 1.5
97	Lucerne	760 - 800	1.4	1.5
98	rye	640 - 760	1.5	> 1.5
99	Other:			
100	dry soil	1 300 – 1 400	0.8	0.9
101	Wet soil	1 900 – 2 100	0.5	0.6
102	fresh peat	700 - 850	> 1.5	1.3
103	Gardening soil	250 - 350	> 1.5	> 1.5

Source: "The technology of machine works in agriculture", PWN, Warsaw 1985

\* - Loading height to obtain a 13,8T weight of the load

 <p><b>CAUTION!</b></p>	<p><b>CAUTION!</b></p> <p>It is advised to aim at an even distribution of the load in the loading crate.</p>
---	--



**CAUTION!**

**CAUTION!**

It is prohibited to exceed the admissible trailer load, because it threatens the safety of road traffic and causes damage to the machine.

Before driving the trailer, check that the swivels connecting the load crate with the lower frame are inserted into the holes and secured against falling and that the walls locks (upper and lower) are closed and secured against accidental opening.

The rope fastening the tarpaulin is installed correctly on all hooks and sufficiently tight.



**CAUTION!**

**CAUTION!**

Overloading the trailer, incompetent loading and securing the load is the most common cause of accidents during transport.

The load must be arranged so as not to threaten the stability of the trailer and not obstruct driving the set.

Observe that there are no bystanders in the zone of unloading / loading or the lifted loading crate. Before tipping the crate, ensure that there is visibility and make sure that there are no bystanders nearby.

The distribution of load may not cause an overload of the chassis, and the trailer hook system.

 <p><b>CAUTION!</b></p>	<p><b>CAUTION!</b></p> <p>It is strictly forbidden to drive with a lifted load crate and transport people on the trailer.</p> <p>While driving, the steering angle (left and right) of the front axle of the trailer should not exceed 90°.</p>
--	---

### 4.3.6 Load transport

When driving on roads (public and private) you must adapt to the traffic regulations, be guided by prudence and reasonable conduct. Below are the most important tips to steer the tractor with an attached trailer.

- Before starting, make sure that in the vicinity of the trailer and the tractor there are no bystanders, especially children. Ensure sufficient visibility.
- Make sure that the trailer is properly connected to the tractor, and the tractor hitch is properly secured.

 <p><b>CAUTION!</b></p>	<p><b>CAUTION!</b></p> <p>Before driving, make sure that:</p> <ul style="list-style-type: none"><li>• the trailer braking system is connected to the tractor and works properly</li><li>• the trailer hydraulic system is connected to the tractor and works properly</li><li>• the trailer electric installation is connected to the tractor and works properly</li></ul>
---	--

- The trailer must not be overloaded, the load must be uniformly distributed so as not to exceed the permitted pressure on the trailer axle chassis. Exceeding the maximum load capacity of the vehicle is prohibited and may cause damage to the machine, as well as pose a risk when traveling

on the road for the operator of the tractor and trailer or other road users.

- Do not exceed the maximum construction speed and speed limitations resulting from road traffic law. The travel speed must be adapted to the prevailing road conditions, trailer load, type of cargo and other conditions.
- The trailer can be towed on slopes of up to 8° and unloading must be carried out only on level ground.
- The trailer disconnected from the tractor must be secured by immobilizing it with a parking brake and planting chocks under wheels. Leaving the trailer unsecured is prohibited. In case of failure of the machine, stop on the roadside, without endangering other road users and mark the spot in accordance with the rules of the road.
- During travel on public roads, the trailer must be marked with a plate distinguishing slow-moving vehicles, attached to the rear wall of the loading crate if the trailer is the last vehicle in the group.
- The operator of the trailer is obliged to equip the tractor trailer with a certified or approved warning reflecting triangle.
- When driving, observe the traffic rules, signal the change of direction with indicators, keep clean and take care of the technical condition of the lighting and signaling installation.
- Damaged or lost lighting and signaling elements are to be immediately repaired or replaced.
- Avoid ruts, depressions, ditches or driving on slopes of the road. Driving through such obstacles can cause sudden tilting of the trailer and tractor. This is particularly important because the center of gravity of the loaded trailer (especially with a volumetric load), adversely affects safety. Driving near the edge of ditches or channels is dangerous because of the risk of landslides under the wheels of the trailer or tractor.

- The driving speed must be reduced early enough before driving to the corners, when driving on uneven or sloping terrain.
- When driving avoid sharp corners, especially on slopes.
- Please note that the braking system increases significantly with increasing mass of the traffic load and increase in speed.
- Control the behavior of the trailer while driving on uneven terrain, and adjust the speed to local conditions and traffic.
- The trailer is adapted for driving on slopes up to 8°. Moving the trailer through the grounds of the steeper slopes may cause the trailer to tip over as a result of loss of stability. Prolonged moving on an incline poses a risk of loss of braking efficiency.

### 4.3.6 Crate unloading

The trailer is equipped with a hydraulic tipping system, and a proper frame and loading crate construction allowing tipping sideways and backwards.

Tipping the load box is controlled with the help of a distributor of the external tractor hydraulic system.

Automated unloading should be done by doing the following while maintaining their order:

- Set the trailer on a flat surface with no twisted front wheels (drawbar directed to driving straight ahead).
- Brake the tractor and trailer with a parking brake.
- Remove two swivels connecting the load crate with lower frame (Fig. 14) from the holes on the opposite side in regards to the place of dumping the load, that is:
  - while unloading from the back - the front swivels 1 and 2
  - when unloading to the left side - the swivels 1 and 3

from the right side of the trailer,

- when unloading to the right side - swivels 2 i 4 from the left side of the trailer.
- Check that the swivels on this side of the trailer to which the unloading will be made are properly established.
- Open or close the lower locks or the wall locks on the side of the trailer, to which the unloading will take place.
- Cause tilting of the load crate by raising it with a telescopic cylinder. Previously, you should position the lever of the shut-off valve of the hydraulic system, which is at the front of the trailer to position "1".



**CAUTION!**

**CAUTION!**

Before tipping the loading crate, check whether the walls or window chute on this side of the trailer to which the tipping will be performed are open.

Tilting the load crate with closed walls or dump window can damage the trailer!

After unloading:

- leave the loading crate,
- Clean the edges of the floors and walls.
- Replace and secure the swivels connecting the load crate with the lower frame
- Close and secure the walls and the extensions or the dump window. Set the locks in a position enabling automatic opening.

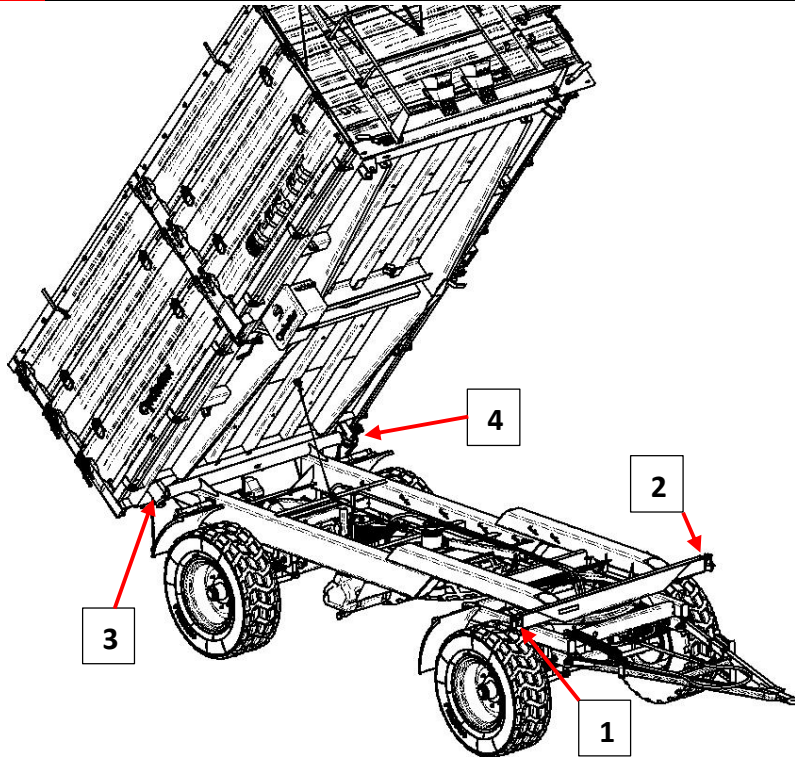

**Fig. 14. Connecting the loading crate with the frame**

1- front right swivel, 2 – front left swivel, 3 – rear right swivel, 4 – rear left swivel

In the case when the second trailer is connected, its unloading should be performed only when the loading crate of the first trailer has been lowered and the valve controlling the tipping hydraulic has been moved in position 2 – second trailer tipping.

Opening or closing the lock of the loading crate requires moving handle 1 (fig. 14) in the right direction while pressing button 2 located under the handle



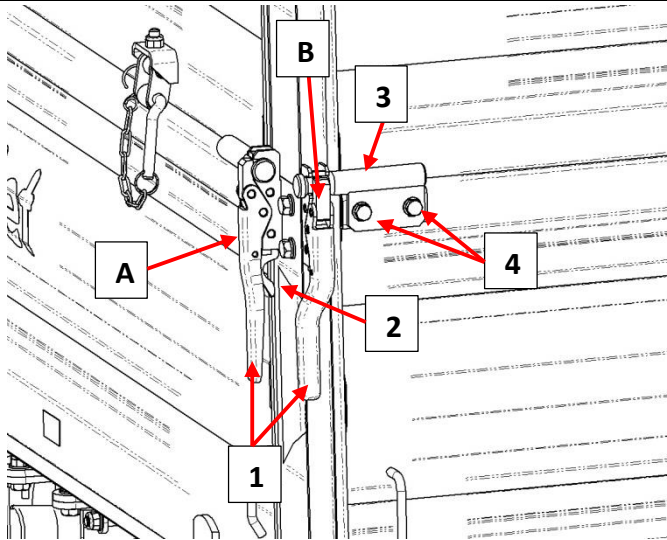

**Fig. 15. Loading crate locks.**

A- side wall lock, B – rear wall lock, 1 – handle, 2 –button releasing the lock, 3 - swivel, 4 – screws locking the rear wall

The rear wall of the loading crate is equipped with a dump window with dimensions of 400x300 mm, which can be opened to give a gap of varying sizes. This allows you to adjust the stream of bulk materials discharged from the trailer, such as mineral fertilizers or grain.



The special gutters mounted in the dump window greatly facilitate the unloading of bulk materials into bags, containers, etc. Opening the sliders of the dump window requires prior loosening of the nuts of the securing clamp. If you use the dump window, do not open the locks of the rear wall.

To realize the unloading of bulk materials through the dump window, you should:

- open the slider of the dump window
- at the moment of a visible reduction in the flow of discharged materials, gently lift the loading crate until

obtaining the desired stream

Lifting the loading crate too high may result in the material advancing on the rear wall and will damage it!!!

 <p><b>CAUTION!</b></p>	<p><b>CAUTION!</b></p> <p>Before starting self-unloading by tipping the loading crate, you must check whether the swivels have been removed and the walls) opened on the right side of the crate.</p> <ul style="list-style-type: none"> <li>• <b>LACK OF REMOVAL OF SWIVELS POSES A THREAT OF DAMAGING THE TRAILER!</b></li> <li>• <b>REMOVING THE WRONG SWIVELS POSES A THREAT OF DESTROYING THE TRAILER!</b></li> <li>• When opening and closing the wall locks, keep caution due to the pressure of the load on the wall!</li> <li>• Unloading bulk materials that have been loaded to a height of more than 1 m can be realized only by tilting the load crate backwards.</li> <li>• Observe that during unloading no one is in the surroundings of the tilted loading crate and the load being dumped.</li> <li>• It is forbidden to move off and drive with a lifted load crate.</li> <li>• It is forbidden to jerk the trailer forwards if the volumetric or harsh-dumping material has not been discharged</li> </ul>
 <p><b>CAUTION!</b></p>	<p><b>CAUTION!</b></p> <p>Unloading the trailer load crate is possible only:</p> <ul style="list-style-type: none"> <li>• when the trailer is connected to the tractor</li> <li>• on a flat and stable surface</li> <li>• without people in the unloading area</li> <li>• when there are no strong transverse gusts of wind</li> </ul>

**CAUTION!****CAUTION!**

Be extremely careful when opening and closing walls and dump windows because of the risk of crushing the fingers or hands.

**CAUTION!****CAUTION!**

Controlling lifting or lowering the load crate can take place only from the seat of the driver of a vehicle towing the trailer and controlled by a valve (hydraulic valve) mounted on the towing vehicle, and the control device of the valve should require support.

## 5. Equipment and accessories

Table 3 Trailer Equipment

Equipment	Standard	Option
User manual	•	
Warranty Card	•	
Connecting cable of the electrical system	•	
Chocks under wheels	•	
Two-wire pneumatic installation	•	
Wheel fenders	•	
Central extensions of the loading crate		•
Spare wheels with a hanger		•
Tarpaulin with a rack		•
Front platform		•
Chute gutter		•
Depreciated automatic rear hitch		•
Electrical installation with LED lamps		•
Toolbox		•
Water tank with a container for soap		•



**CAUTION!**

**CAUTION!**

- Assembly and disassembly of extensions, frame and tarpaulin should be performed with the use of appropriate platforms, ladders or a ramp. These jobs should be carried out by two people at the same time with keeping caution and protecting workers from falling.
- The spare wheel is suspended at the lower frame of the trailer. Before replacing the wheel, brake the trailer with a parking brake and prevent it from rolling away (e.g. by planting wheel chocks). The loading crate in such a case cannot be raised.

## 6. Technical Support



When using the trailer, constant monitoring of the technical condition and the execution of maintenance procedures is needed that will keep the vehicle in good Technical condition. Therefore, the user of the trailer is obliged to perform all maintenance and regulatory tasks specified by the Manufacturer.

In order to function properly and to avoid serious failure of the trailer, it must be kept in good condition, repaired on time and reasonably operated (operation within the technical parameters of the trailer).

An important element of the operation is the daily maintenance of the trailer (before work), it foresees:

- control of tightening the screw connections and securing them against unauthorized untightening,
- checking the tightness of the hydraulic system
- checking the tightness of the pneumatic system,
- check the correct operation of the mechanisms,
- check the functioning of the brake system,
- check the functioning of the electrical system,
- checking and performance of lubrication, as indicated by the instructions,
- checking the tire pressure
- checking the wall and extensions lock - whether they are properly closed and secured and there is no risk of spontaneous opening

Any faults detected should be removed on a regular basis, use of the trailer, even with a slight failure could have serious consequences.

 <p><b>CAUTION!</b></p>	<p><b>CAUTION!</b></p> <p>If you need to lift the wheels of the trailer, observe the following rules:</p> <ul style="list-style-type: none"> <li>• Set the trailer attached to the tractor in the direction for driving straight ahead on a flat, paved ground and then brake the tractor.</li> <li>• Under the wheels, which will not be lifted, plant securing chocks.</li> <li>• Place a lift under the axle close to the lifted wheel and raise the axle so that the wheel does not touch the ground.</li> <li>• Secure the trailer before falling placing a stand of appropriate height under the axle.</li> </ul>
 <p><b>CAUTION!</b></p>	<p><b>CAUTION!</b></p> <ul style="list-style-type: none"> <li>• In the case of noting any irregularities in the operation or damage to systems or assemblies of the trailer, the machine must be taken out of use until repair and removal of defects.</li> <li>• It is forbidden to carry out service and repair work under a loaded or raised and unsupported loading crate.</li> <li>• All maintenance and repair tasks should be performed with the general principles of health and safety. In the case of injury, the wound should immediately be washed and disinfected. In case of serious injuries, consult a physician</li> <li>• If necessary, perform maintenance and repair work under the lifted load crate (e.g. replacement of the telescopic cylinder), the loading crate should absolutely be secured with a service support 1 (fig. 16).</li> </ul>

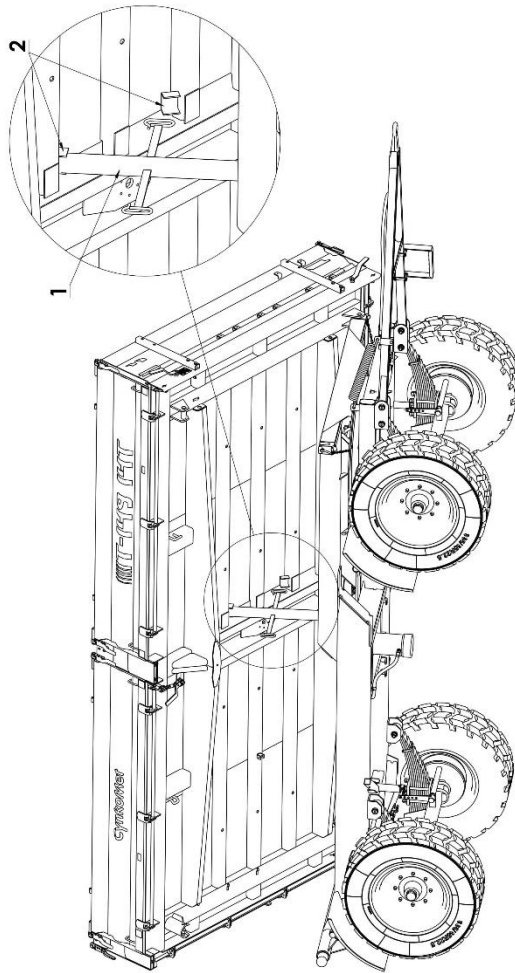

**Fig. 16. Way of supporting the loading crate**

1 – crate support, 2 – support socket

If, for maintenance tasks, raising the crate is necessary, it should be tipped aside and secured before reclining the support of the loading crate (fig.16 p.1).

In the frame of container, there are sockets of the crate support (fig.16 p.2). The crate should be lifted by a hydraulic cylinder, then paying particular attention to safety, raise the



crate support and slowly lower the loading crate direct the support to the socket.

The loading crate cannot be loaded. The trailer must be connected to the tractor and secured with chocks and locked with a parking brake.

## **6.1 Regulation of driving wheel bearings backlash.**

In a newly purchased machine, after the first 100 km, while during further use - after driving another 1500- 2000 km - check and if necessary adjust the backlash of the wheel bearings. To do this you need to:

- Connect the trailer to the tractor, set such a set on a hard surface in the direction of driving straight ahead (front axle of the trailer may not be twisted)
- Brake the trailer.
- Place the blocking wedges under the wheels of a trailer, raise the trailer wheel on the opposite side of the wedges so that the wheel does not touch the ground and secure it from falling.
- Check the backlash:
  - By turning the wheel slowly in both directions, check that movement is smooth, and if the wheel rotates without excessive resistance and jams
  - Spinning the wheel so that rotates very quickly, check that the bearings do not make unnatural sounds.
  - Moving the wheel, try to feel the backlash.
  - Repeat for each wheel individually, remembering that the lift must be on the opposite side of the wedges

- If the wheel shows excessive backlash, a regulation should be carried out:
  - remove the hub cap by prying it out with a screwdriver in several places around the circumference and remove the cotter pin of the castellated nut.
  - Turning the wheel, simultaneously tighten the castellated nut until the wheel stops completely.
  - Unscrew the nut by 1/6 -1/3 turn, until covering the next groove on the pin with a hole in the pivot. The wheel should turn without excessive resistance, the nut cannot be tightened too much. It is not recommended to use too strong pressure due to the deterioration of the working conditions of bearings.
  - Secure the nut with a new cotter pin, and firmly press the hub cap.

The mentioned steps should be repeated checking the remaining wheels.

The wheel, after correct adjustment of the bearings should turn smoothly without stops and perceptible resistance.

The soundness of bearings backlash has to be finally checked after driving a few kilometers with the trailer controlling the degree of the hubs heat by hand.

The cause of the occurrence of significant resistance when turning the wheel, and strong heating of the hubs apart from improper adjustment of the bearings backlash can be contaminants in the lubricant or bearing damage. The above symptoms require dismantling the wheel hub and removing the fault (replacement of grease or bearings).

## 6.2 Brakes regulation.

Brakes regulation should be carried out if:

- brakes of both wheels brake unevenly and / or non-simultaneously.
- expander levers are not parallel to each other during braking.
- a repair of the brake system was carried out.

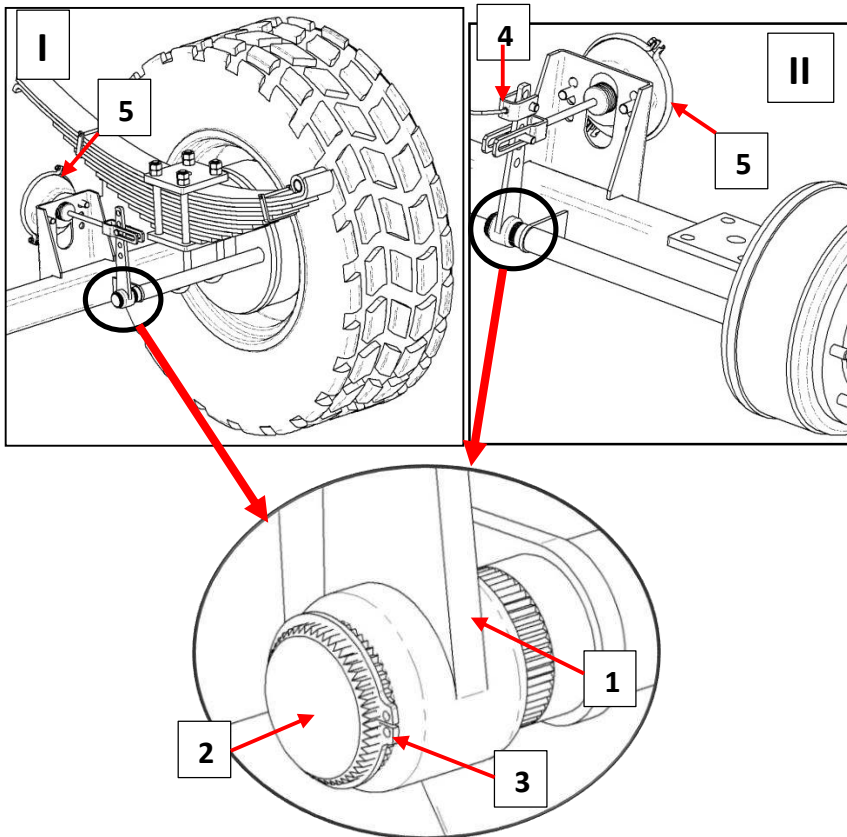

**Fig. 17. Brakes regulation**

I – front axis, II – rear axis, 1 – expander arm, 2 – expander roller, 3 - retaining ring (Seeger), 4 - hand brake cable, 5 – brake cylinder

With properly adjusted brakes, complete braking of both wheels should take place at the same time.

Brakes adjustment involves changing the position of expander arm 1 (fig. 17) with respect to the expander roller 2. To do this, remove the retaining ring 3 of roller 2, and then remove arm 1 of shaft 2. Then move the expander arm on the conjunction with the roller by one or more teeth in the right direction, namely:

- back - if the brake is too late;
- forward - if the brake is too early.

Once the proper position of the arm 1 is achieved relative to expander roller 2, you must tighten nut 4.

The adjustment should be conducted separately for each trailer wheel. After proper brake adjustment, at full braking, the expander arms should form an angle of  $90^\circ$  with the piston rod of the actuator, and the spring should be about half the length of the spring of the total piston rod. After releasing the brake, the expander arms may not be based on any structural elements, because too little withdrawal of the piston rod can cause friction of the jaws against the drum and result in overheating of the trailer brakes. The expander arms arranged on one axis must be parallel to each other at full braking. If not, adjust the position of the lever, which has a longer spring. When removing, the actuator fork you must remember or mark the original setting of the swivel of the actuator fork. The mounting position is chosen by the manufacturer and cannot be changed.

## 6.3 Brakes regulation.

As part of routine maintenance, check the tightness of the pneumatic system (pay most attention to places of all connections). If the conduits, seals or other components are damaged, compressed air will penetrate outside with a typical hiss. The damaged seals or conduits causing leaks should be replaced.

Periodically, remove the condensate gathering in the water from the air tank. For this purpose, pull out the mandrel of the drain valve at the bottom of the tank to the side. The compressed air in the tank will push the water out. After releasing the mandrel, the valve should automatically close and stop the airflow from the tank.

Once a year, before the winter, unscrew the drain valve and clean off the accumulated dirt.

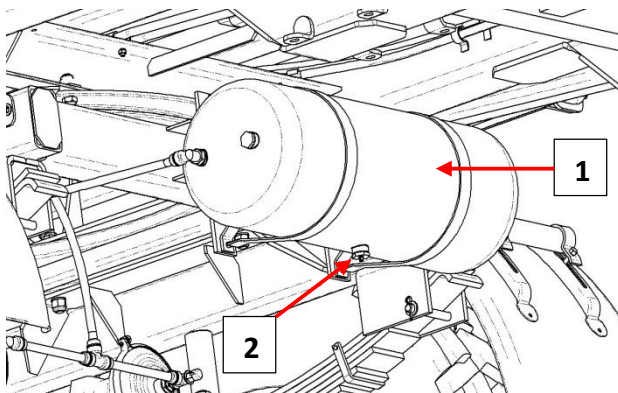
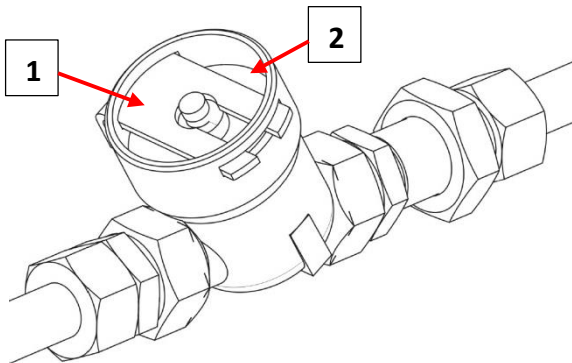

**Fig. 18. Draining the air tank**

1 - air tank, 2 drain valve

	<b>CAUTION!</b> Before dismantling the drain valve, reduce the pressure in the air tank.
---	---

Depending on the operating conditions of the trailer, but not less frequently than once every three months, remove and clean the air filter inserts, which are located on the pneumatic system connection cables. The inserts are reusable and cannot be replaced unless they are damaged by mechanical means.



**Fig. 19. Wired air filter**

1 - filter cover protection, 2 - filter lid

	<b>CAUTION!</b> Before demounting the air filters, reduce the pressure in the brake system.
---	--

## 6.4 Hydraulic installation maintenance.

Always follow the principle that the oil in the trailer hydraulic system and the oil in the external tractor hydraulic system are to be of the same type. The use of different types of oil is not permitted.

The hydraulic system of the trailer should be absolutely tight. Checking tightness of the hydraulic system consists of connecting the trailer to the tractor, running the hydraulic cylinder and storing it in the position of the maximum extension of the cylinder with the loading crate tilted for 30 seconds.

In the case of noticing oil leaks on connections of hydraulic conduits, you must tighten the connector, if this does not rectify the fault, replace the conduit or the connector with a new one. If the oil leak occurs beyond the connection, the leaking conduit system should be replaced. Exchange of a component to a new one is also required for any damage of mechanical nature.

Hydraulic hoses should be replaced at least every four to six years from their date of manufacture, unless previously found to be damaged and replaced.

In the case of noting oiling on the body of the hydraulic cylinder, check the nature of the leak. When fully taking out the cylinder actuator, check all sealing places. Minor leaks with symptoms of "sweating" are acceptable, but if you see a leak of a "drip" type, you must stop the operation and repair the failure.

**CAUTION!****CAUTION!**

Operation of the trailer with a leaking tilting hydraulic system is unacceptable. Using a trailer with a leaking tilting hydraulic system is unacceptable.

## 6.5 Handling the spring leaf system.

Operation of the spring leaf is based on controlling the current state of spring leaves. These springs should be kept covered with a thin layer of grease. It should not be allowed to accumulate a thick layer of dried mud on the springs.



 <p><b>CAUTION!</b></p>	<p><b>CAUTION!</b></p> <p>In the case of noticing a crack of a spring leaf in any of the springs, the trailer should be out of operation until the fault has been rectified.</p>
--	--

## 6.6 Handling electrical equipment.

The work connected with the repair, replacement or regeneration of electrical components should be entrusted to specialized workshops, which have the appropriate technology and qualifications for this type of work.

The duties of the user include only:

- technical inspection of electrical installations and reflectors,
- replacing light bulbs.

 <p><b>CAUTION!</b></p>	<p><b>CAUTION!</b></p> <p>Driving with a faulty lighting system is prohibited. Damaged shades, and burned-out bulbs must be replaced immediately before driving.</p> <p>Lost or damaged reflective lights must be replaced with new ones.</p>
--	---

## 6.7 Lubrication.

Lubrication of the trailer should be carried out in the points specified in Figure 20 and listed in Table 4

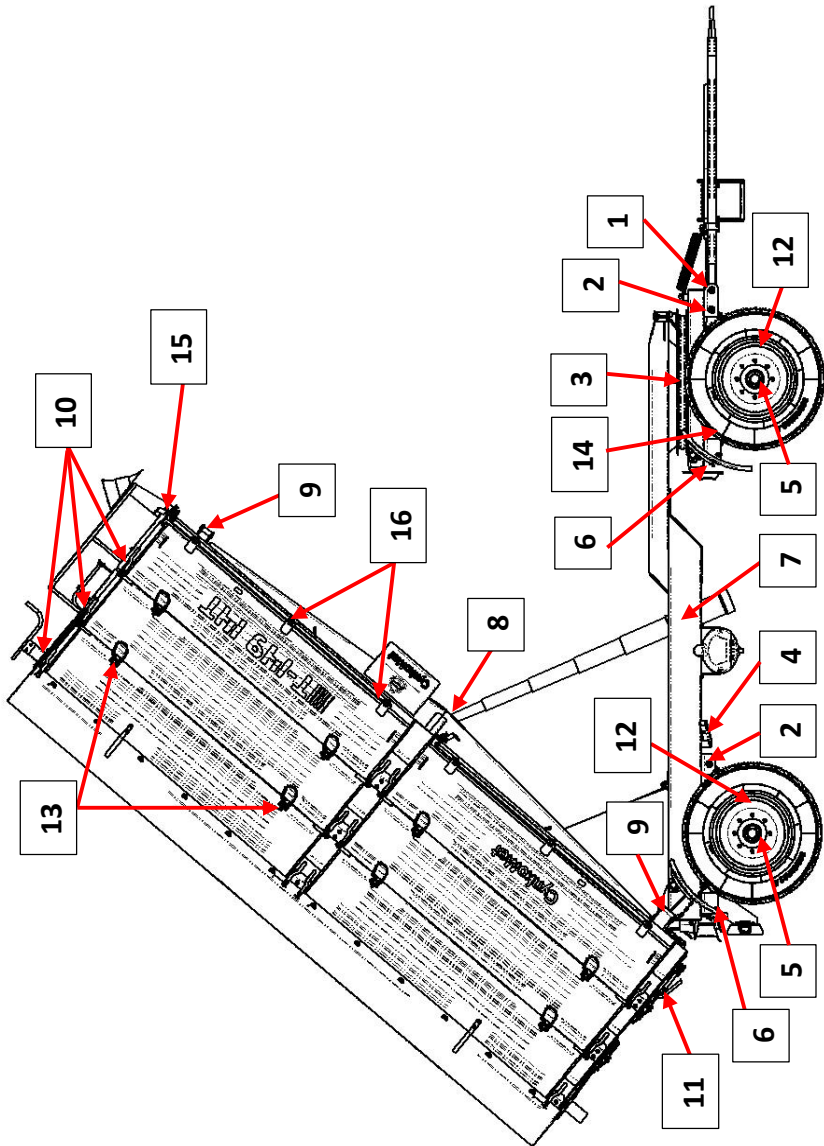

Fig. 20. Lubrication diagram

**Table 4. The frequency and method of lubrication of the trailer mechanisms**

No. on fig. 14	Place of lubrication	Number of lubrication points	Grease type	The frequency and method of lubrication
1	Drawbar swivels	2	Permanent grease	Every 3-4 months.
2	Spring leaves swivels	4	Permanent grease	Every 3-4 months.
3	Turntable	1	Permanent grease	Ever 6-8 months.
4	Screw of the parking brake crank	1	Permanent grease	Every 2 months, cover the surface with fresh grease.
5	Driving wheels bearings	4	Permanent grease	Every 3-4 months.
6	Leaf spring sliders	4	graphite grease	Every 3-4 months spread grease on the surface of the slider with a loaded leaf spring
7	Swivels of the of the lower hydraulic cylinder suspension	4	Permanent grease	Every 6 months cover the swivels with fresh grease.
8	The top ball joint of the hydraulic cylinder	1	Permanent grease	once a year cover the ball pin with fresh grease.
9	Sockets of the	4	Perma	Every 2 months,

	loading crate planting		nent grease	Lubricate surfaces.
10	Wall locks and loading crate flap	20 or 30	Oil	Once a month.
11	Guides of dump windows	2	Perma nent grease	Every 3-4 months cover with a very thin layer of grease.
12	Expanders bars	4	Perma nent grease	Fill the grease every 6 months.
13	Hinges extensions	10 or 20	Perma nent grease	Once a month, lubricate the swivels.
14	Spring feathers	4	Perma nent grease	Every 6-8 months
15	The levers of the lower walls locks	5	Perma nent grease	Every 3-4 months.
16	Wall hinges	16	Perma nent grease	Every 3-4 months.

Before commencing the lubrication of the grease fitting, the greased surfaces and places nearby lubrication points must be thoroughly cleaned of mud and dust. The grease should be injected in the grease fitting until release of fresh grease in the gaps between the mating parts.

## 6.8 Storage and maintenance.

After ending operation, the trailer must be carefully cleaned and washed with a stream of water, and then left it in a dry and ventilated area. In the event of failure of these

actions on the zinc coating, dark and light gray areas (spots) may occur, which do not constitute grounds for complaint if the zinc coating still has the required minimum thickness (PN-EN ISO 1461: 2000). In the case of damage of the external paint coating, the damaged areas must be cleaned of rust and dust, degreased, and painted retaining the same color and uniform thickness of the protective coating. Until painting, the damaged areas should be covered with a thin layer of grease or anticorrosion preparation.

During a long break in the use of the trailer, it is desirable to place it indoors or in a covered, ventilated place. It is also advisable that the metal parts not coated with paint are secured with an anti-corrosion preparation of temporary protection or a layer of grease. During a long break in the use of the trailer it cannot be loaded.

## 6.9 Troubleshooting.

Table 5. Faults and remedies

Fault	Reason	Way of removal
Problems with moving	Unconnected hoses Of the brake installation	Connect the brake hoses
	launched parking brake	Release the parking brake.
	Damaged connection cables of the pneumatic system	Exchange.
	Connections leakage	Tighten, replace washers or seal sets, replace the cables.
	Damaged control	Check the valve,

	valve or brake force regulator	repair or replace it.
Noise in the hub of the driving axle	Excessive neutral gear on the bearings	Check the neutral gear level and if necessary regulate
	defective bearings	replace bearings
	damaged items	Exchange

Table 5. Faults and remedies

Fault	Reason	Way of removal
Low efficiency of the braking system Excessive heating of the driving axle hub	Pressure too low in the system	Check the pressure gauge on the tractor, wait till the compressor fills the tank to the required pressure.
	Improperly adjusted essential or parking brake	Adjust the position of the spreader arms
	Worn out brake linings	Replace the brake shoes
	Installation leakage.	Check the installation for leaks.
	Damaged air compressor in the tractor.	Repair or replace.
	Damaged brake valve in the tractor.	Repair or replace.

Table 5. Faults and remedies

Fault	Reason	Way of removal
Improper operation of the hydraulic system	Improper hydraulic oil viscosity	Check the quality of oil, make sure that the oil in both machines is of the same type. If necessary, replace the oil in the tractor and / or trailer
	Insufficient efficiency of the tractor hydraulic pump, damaged tractor hydraulic pump.	Check the hydraulic pump on the tractor.
	Damaged or contaminated actuator	Check the cylinder piston (bending, corrosion), check the cylinder for tightness (piston rod sealing), if necessary, repair or replace the actuator.
	Too much actuator load	Check and, if necessary, reduce the load on the actuator
	Damaged hoses	Check to make sure that the hydraulic hoses are tight, not refracted and properly looped. If necessary, replace or tighten.

## 7. Transport

The trailer is prepared for sale in a fully assembled state and does not require packing. Only technical - physical documentation of the machine and the cable connection of the electrical system are subject to packing, and as to the optional accessories: the warning triangle, tarpaulin with a frame and plate distinguishing slow-moving vehicles.

The supply of the trailer to the user is done by independent transport after connecting with the tractor or automobile (in this case, the trailer because of the height can be mounted on the platform of the transport mean on the hubs - with unscrewed and taken off wheels or on wheels, but with disassembled and folded upper extensions

Loading and unloading a trailer from a car should be carried out using the loading ramp with a tractor or using a crane or lever. During operation, observe the general safety rules with handling operations. Persons operating the reloading equipment must have the required permissions to use these devices.

When loading / unloading using the tractor, the trailer must be properly connected with the tractor according to the requirements contained in this manual. The trailer braking system must be running and tested before running off or driving on the ramp.

When loading / unloading the trailer by crane or lever to lift, lift it with the help of approved fasteners designed to carry the load with sufficient capacity. The belts must be in good condition, they cannot show any signs of damage.

The belts should be placed under the lower frame of the trailer in such places that when lifting the trailer the belts



do not have the possibility of moving, and the trailer when moving is not tilting. If there is a possibility of damage or frayed belts against components of the trailer, put washers in sensitive areas.

In order to avoid compression of the walls inside the trailer, when loading using a crane, use a special traverse, in which the places of hooking the belts are spaced wider than the total width of the trailer.

The trailer should be attached firmly to the platform of the transport mean with belts, chains, lashing or other fastening means fitted with a tightening mechanism. The fasteners should be hooked in the designated eyebolts Fig.21 or permanent structural elements of the trailer (cross-braces, crossbars, etc.). Transport handles are welded to the chassis of the top frame, one pair on each side of the trailer. Use certified and technically efficient fastening means. Frayed belts, cracked mounting brackets, opened or corroded hooks or other damage may disqualify the given mean for use.

Under the wheels of the trailer chocks, it is advisable to put wooden beams or other elements without sharp edges, preventing the machine from rolling. Trailer wheels chocks must be attached to the loading platform of the car so as to prevent their shifting.



**CAUTION!**

**CAUTION!**

During car transport, the parking brake should be used in the trailer (parking brake action is described in section 4.2.4).

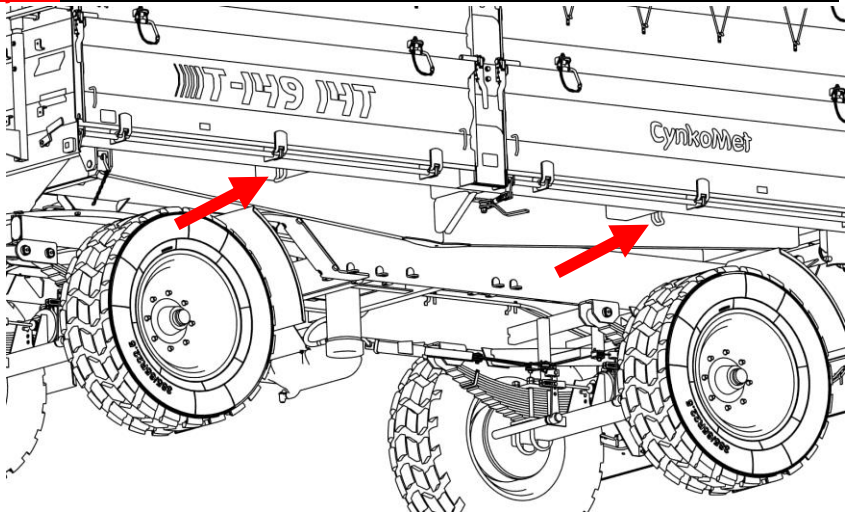

Fig. 21. Transport handles



**CAUTION!**

During independent transport, the trailer operator should be familiar with the contents of this manual and follow the recommendations contained in it. During road transport, the trailer is mounted on a platform of the transport mean in accordance with the manufacturer's technology. The driver of the car, while transporting the machine, should take extra caution. This is due to the upward movement of the vehicle's center of gravity with a loaded machine.

## 8. Trailer cassation

Should the user make a decision on withdrawal of the machine, you must pass the entire trailer to the scrap depot designated by the Governor or a Starost.

The certificate obtained from this facility is the basis for the de-registration of the trailer.

The dismantled parts remaining after repair must be submitted to the collection point of recyclable materials.

## 9. Guarantee

"CYNKOMET" Sp. z o.o. in Czarna Białostocka ensures the smooth operation of the machine according to the technical-operational terms described in the operating manual. The condition of accepting a complaint is to follow all the recommendations contained in the operating and use manuals.

### ***TERMS OF THE WARRANTY:***

The guarantee will be respected after the presentation by the customer of a clearly and correctly filled warranty card of the machine undergoing reclamation.

- 1) Failures detected during the warranty period will be removed by warranty service no later than 14 working days from the date of delivery by the repair station or any other agreed period.
- 2) In a written notification claim (mail, fax, e-mail, etc.) you must give the data and contact of the owner of the machine, its name, serial number, purchase date and a description of the complaint.
- 3) Parts subject to wear during exploitation are not covered by the warranty e.g. tires, brake linings, lighting, damage caused by external causes, such as: mechanical injuries, improper handling, as well as the operation incompatible with the intended purpose.
- 4) This manual does not allow you to make changes, alterations, modifications to the discretion of the Customer without consulting with the manufacturer.

Detailed warranty conditions are mentioned in the warranty card attached to each newly purchased machine.

 <p><b>CAUTION!</b></p>	<p><b>CAUTION!</b></p> <p>It is advisable to require from the seller to fill in the warranty card and reclamation coupons. Lack of e.g. the date of sale or point of sale stamp exposes the user to non-recognition of any complaints.</p>
--	--

## 10. Environmental hazard

Hydraulic oil leakage is a direct threat to the environment because of the limited biodegradability of the substance.

The created layer of oil on the water can a result of direct physical action on organisms, can cause change in the oxygen content in the water due to absence of direct contact of the air with water.

Maintenance - repair work at the time of which there is a risk of leakage should be performed in rooms with oil resistant surface.

In the event of an oil spill, you must first secure the source of the leak, and then collect the spilled oil using available means. Collect the oil residues using sorbents, or mix the oil with sand, sawdust or other absorbent materials. The collected oil waste should be kept in a sealed and marked container, resistant to hydrocarbons. The container should be kept away from heat sources, flammable materials and food.

**CAUTION!****CAUTION!**

Used hydraulic oil or gathered remains mixed with absorbent material should be stored in a carefully marked container. For this purpose, do not use food containers.

Used oil or unsuitable for reuse due to the loss of its properties should be stored in its original packaging in the same conditions as previously described. Oil waste must be transferred to a point taking care of recycling or oils regeneration. Waste code: 13 01 10. Detailed information concerning hydraulic oil can be found in the safety data sheet.

**CAUTION!****CAUTION!**

Oil waste can be delivered only to the point taking care of disposal or oils regeneration. It is forbidden to throw or pour oil into drains or water.

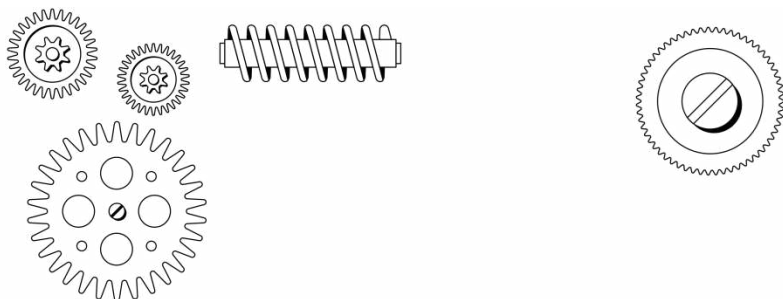

# SPARE PARTS CATALOGUE

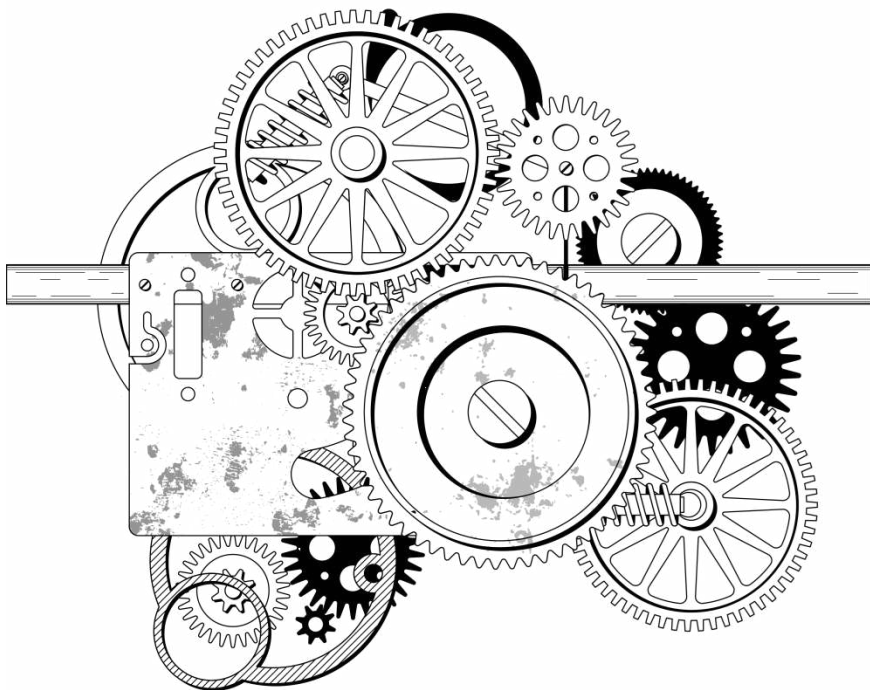





# 11. SPARE PARTS CATALOGUE

## 11.1 Introduction.

The "Spare parts catalog" is next to the "Operating Instructions" the basic technical-motor document designed for trailer users

The catalogue includes:

- drawings of all assemblies and mechanisms of the trailer;
- lists of parts of individual units and mechanisms.

## 11.2 How to use the catalogue.

For each drawing, there is a text table added, containing the list of parts of the unit or the mechanism.

In order to obtain the part number, select an assembly or mechanism drawing, which includes the part from the catalogue, read the number of its position, and then on the appropriate plate, find the appropriate position under this name and part symbol

When ordering please specify:

- the exact address of the contracting authority (recipient of the parts);
- part name compatible with the catalog;
- part number compatible with the catalog;
- the number of pieces of the ordered parts;
- year of production and serial number of the machine.

<b>Push-torsion system .....</b>	<b>100</b>
Table 6. Push-torsion system.....	101
<b>Suspension .....</b>	<b>102</b>
Table 7. Suspension.....	103
<b>Spring suspension.....</b>	<b>104</b>
Table 8. Spring suspension.....	105
<b>Wheel fender.....</b>	<b>106</b>
Table 9. Wheel fender.....	107
<b>Water tank.....</b>	<b>108</b>
Table 10. Water tank.....	109
<b>Upper frame.....</b>	<b>110</b>
Table 11. Upper frame.....	111
<b>Rear closure.....</b>	<b>112</b>
Table 12. Rear closure.....	113
<b>Closure flexible connector.....</b>	<b>114</b>
Table 13. Closure flexible connector.....	115
<b>Walls set.....</b>	<b>116</b>
Table 14. Walls set.....	117
<b>Rear wall.....</b>	<b>118</b>
Table 15. Rear wall.....	119
<b>Extensions set.....</b>	<b>120</b>
Table 16. Extensions set.....	121
<b>Center extensions set.....</b>	<b>122</b>
Table 17. Center extensions set.....	123
<b>Hydraulic installation.....</b>	<b>124</b>
Table 18. Hydraulic installation.....	125

<b>Hydraulic installation continued.....</b>	<b>126</b>
Table 18 continued Hydraulic installation.....	127
<b>Two-wire pneumatic installation .....</b>	<b>128</b>
Table 19. Two-wire pneumatic installation .....	129
<b>Two-wire pneumatic installation continued.....</b>	<b>130</b>
Table 19 continued Two-wire pneumatic installation. ....	131
<b>Handbrake.....</b>	<b>132</b>
Table 20. Handbrake. ....	133
<b>The handbrake mechanism. ....</b>	<b>134</b>
Table 21. The handbrake mechanism.....	135
<b>Toolbox.....</b>	<b>136</b>
Table 22. Toolbox. ....	137
<b>Front platform.....</b>	<b>138</b>
Table 23. Front platform. ....	139
<b>Tarpaulin frame.....</b>	<b>140</b>
Table 24. Tarpaulin frame.....	141
<b>Tarpaulin.....</b>	<b>142</b>
Table 24. Tarpaulin.....	143
<b>Electrical installation .....</b>	<b>144</b>
Table 25. Electrical installation.....	145
<b>Hanger (protection) of the lighting.....</b>	<b>146</b>
Table 26. Hanger (protection) of the lighting. ....	147

# Push-torsion system

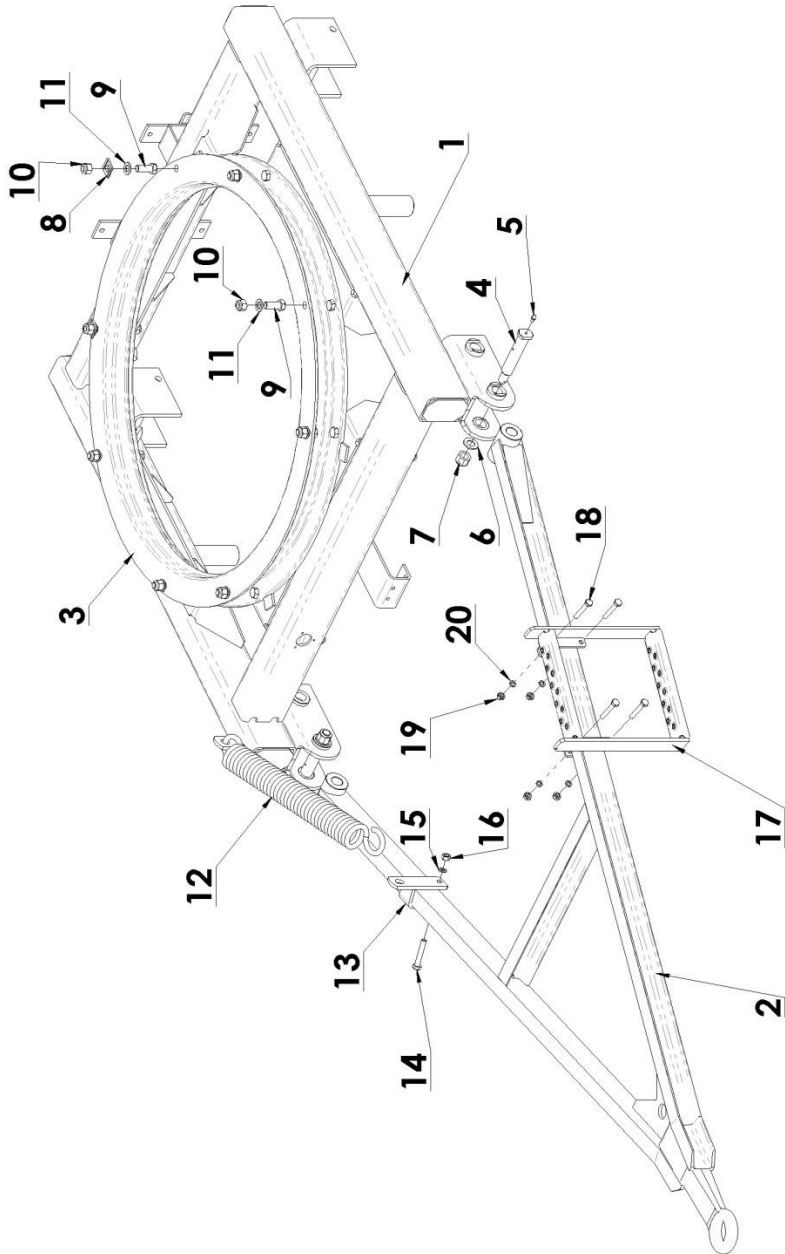

Table 6. Push-torsion system.

Position	Part name	Number	Amount
1	Turntable frame	7149/16.00.000/ 1	1
2	Drawbar	7149/27.00.000/ 2	1
3	10T turntable	7149/00.12.000	1
4	Swivel II	7149/00.00.007	2
5	M6 Grease fitting	PN76/M-86002	2
6	Washer 21	PN-78/M-82005	2
7	M20 Self-locking nut	PN-85/M-82175	2
8	Wedge washer 18	PN-79/M-82018	2
9	M16x45 Screw	PN85/M-82105	16
10	M16 Self-locking nut	PN-85/M-82175	16
11	Washer 17	PN-85/M-82005	16
12	Drawbar spring	7104/00.00.012	1
13	Spring hook	7149/00.00.100	1
14	M12x70-8.8 Screw	PN-85/M-82101	1
15	Spring Washer 12,2	PN-77/M-82008	1
16	M12 Nut	PN-86/M-82144	1
17	Drawbar footer	7104/00.16.000/ 1	1
18	M10x70 screw	PN85/M-82105	4
19	M10 nut	PN-86/M-82144	4
20	Spring washer 10.2	PN-77/M-82008	4

# Suspension

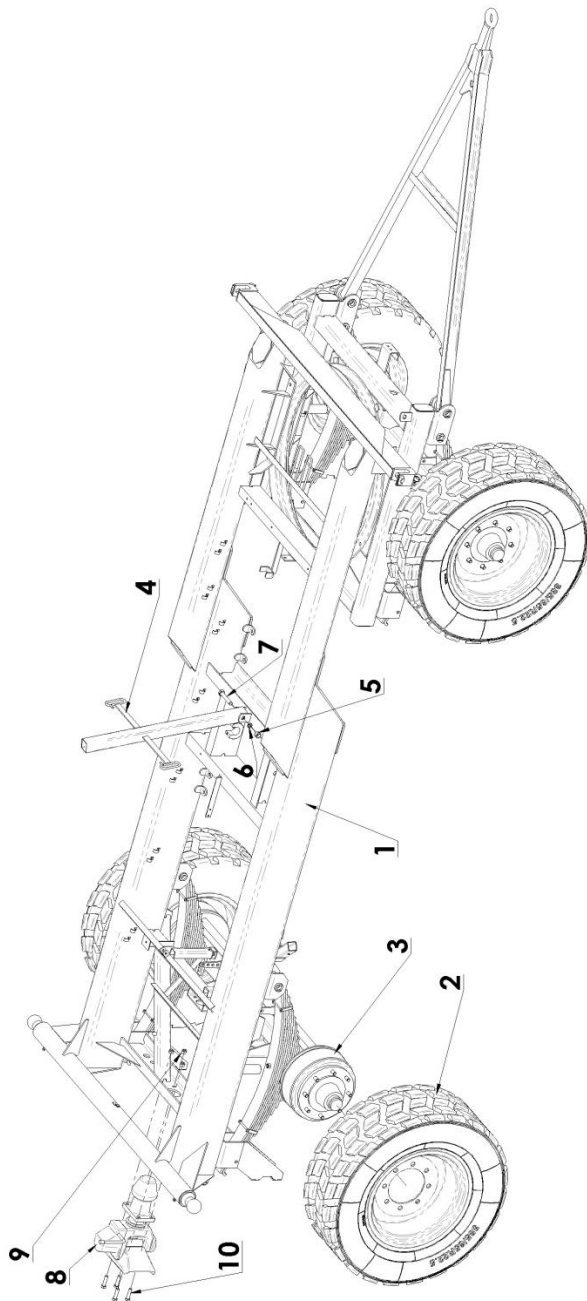

Table 7. Suspension.

Position	Part name	Number	Amount
1	Bottom frame	7149/02.00.000/ 3	1
2	Wheel set	385/65-22.5	4
3	Braked driving axle	7149/25.00.000/ 1	2
4	Crate bracket	7149/00.01.000	1
5	M20 Nut	PN-85/M-82175	1
6	Washer 21	PN-78/M-82005	1
7	M20x110 Screw	PN-86/M-82101	1
8	Automatic suspension hitch	GE504A0	1
9	M16 Self-locking nut	PN-85/M-82175	4
10	M16x60 Screw	PN85/M-82105	4

## Spring suspension

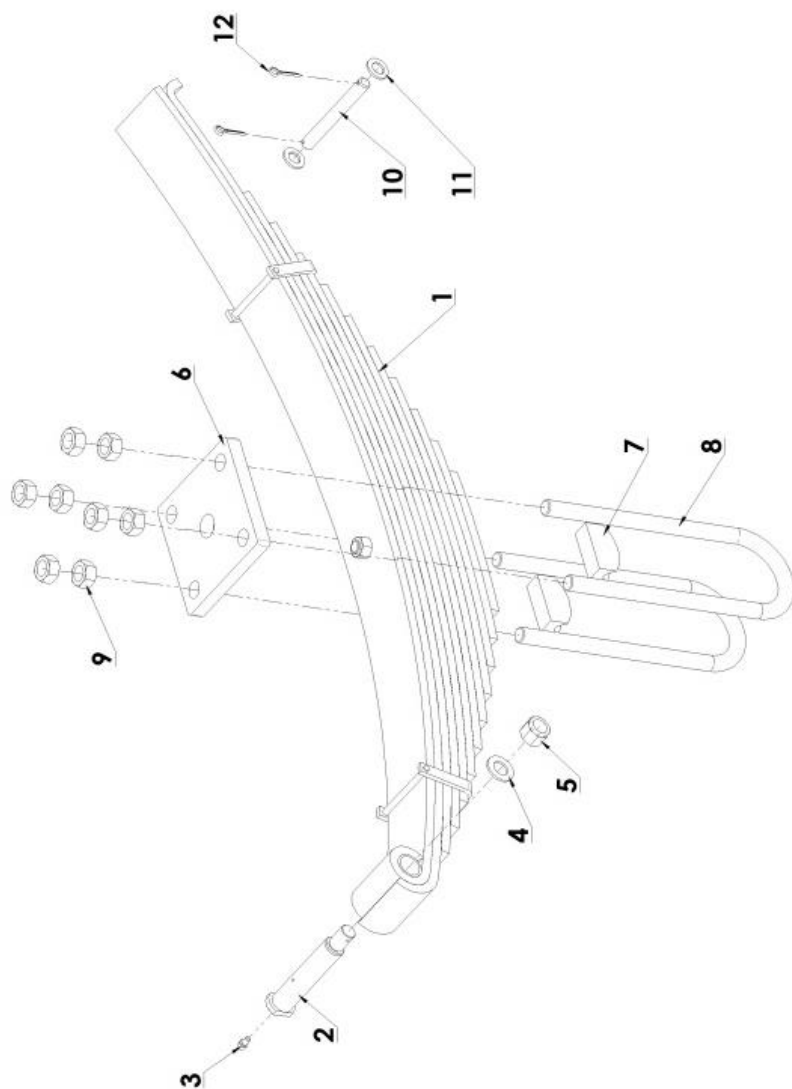



Table 8. Spring suspension.

Position	Part name	Number	Amount
1	Leaf spring	SPMO-92.030	1
2	Swivel II	7149/00.00.007	1
3	M6 grease fitting	PN76/M-86002	1
4	Washer 21	PN-78/M-82005	1
5	M20 Self-locking nut	PN-85/M-82175	1
6	Spring disc	7149/00.00.003	1
7	90" Screw washer	7149/00.00.004/ 1	2
8	90" glomerular screw	7149/00.00.001/ 1	2
9	M20x1,5 Nut	PN-86/M-82144	8
10	Swivel II	7149/00.00.008	1
11	Washer 17	PN-85/M-82005	2
12	S-Zn 4x32 Pin	PN-76/M-82001	2

# Wheel fender

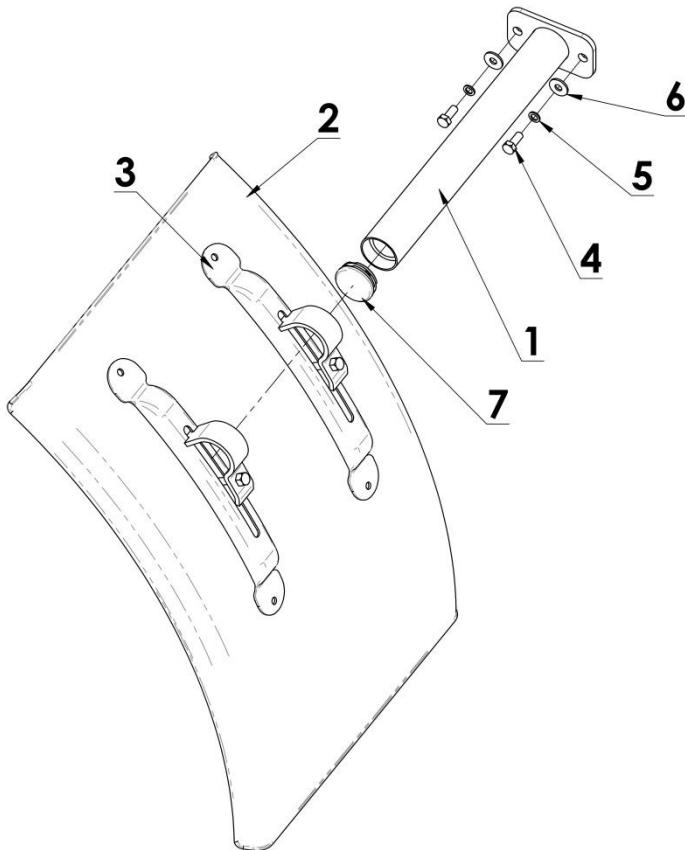

Table 9. Wheel fender.

Position	Part name	Number	Amount
1	Fender bracket	7149/00.02.000	1
2	14 Fender with a 430x650 circuit	P5026069/P5126069	1
3	Fender handle	VR42,4	2
4	M8x20-8,8-B Screw	PN-85/M-82105	2
5	Spring washer 8,2	PN-77/M-82008	2
6	Round washer 8,5	PN-59/M-82030	2
7	Round cap fi45 1-3	111534	1

# Water tank

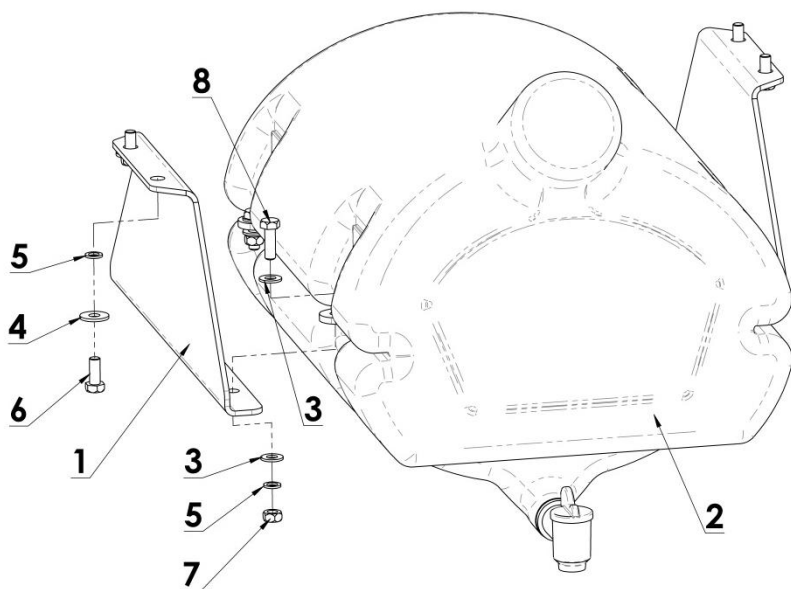

Table 10. Water tank.

Position	Part name	Number	Amount
1	Water tank bracket	7149/00.00.010	2
2	Water tank with a cont. for soap	TK2525	1
3	Round washer 8,4	PN-59/M-82005	8
4	Round washer 8,5	PN-59/M-82030	4
5	Spring washer 8,2	PN-77/M-82008	8
6	M8x20-8,8-B Screw	PN-85/M-82105	4
7	M8 Nut	PN-86/M-82144	4
8	M8x25-8.8 Screw	PN-85/M-82105	4

# Upper frame

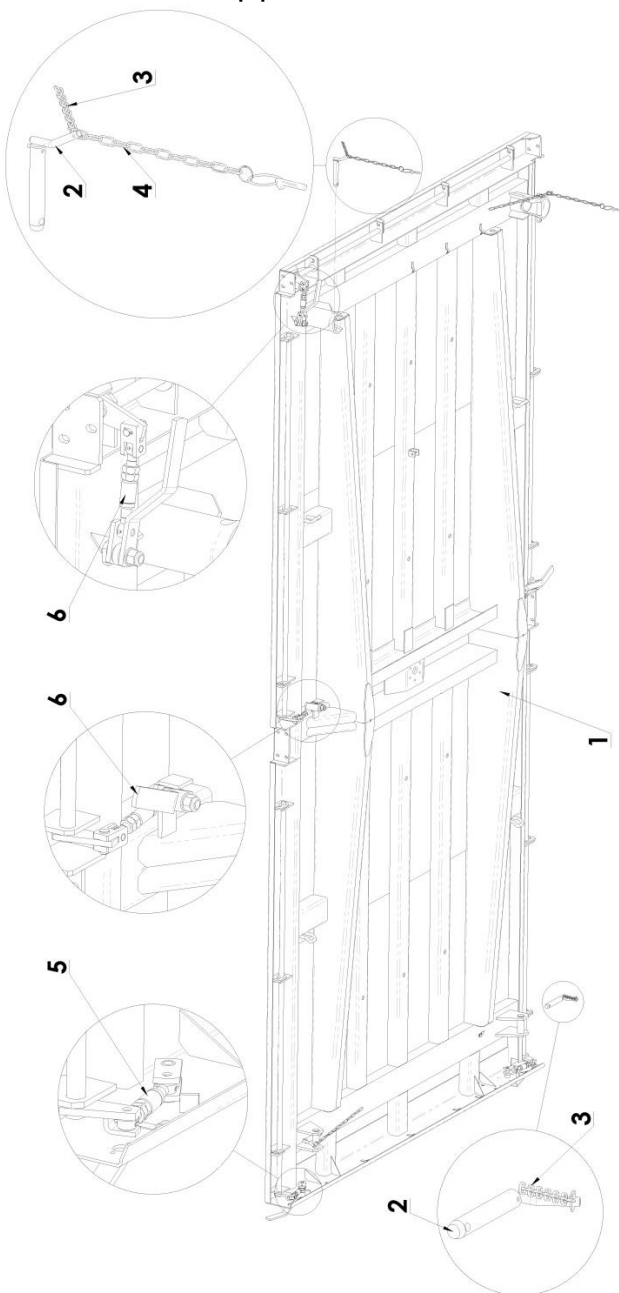

Table 11. Upper frame

Position	Part name	Number	Amount
1	Upper frame	7149/01.00.000/ 2	1
2	Tipping swivel	7104/00.00.700	4
3	Chain set	7076/00.01.000	4
4	Cotter pin set	7169/00.00.300	2
5	Closure flexible connector	7104/00.25.100	2
6	Rear closure	7104/00.25.000	3

# Rear closure

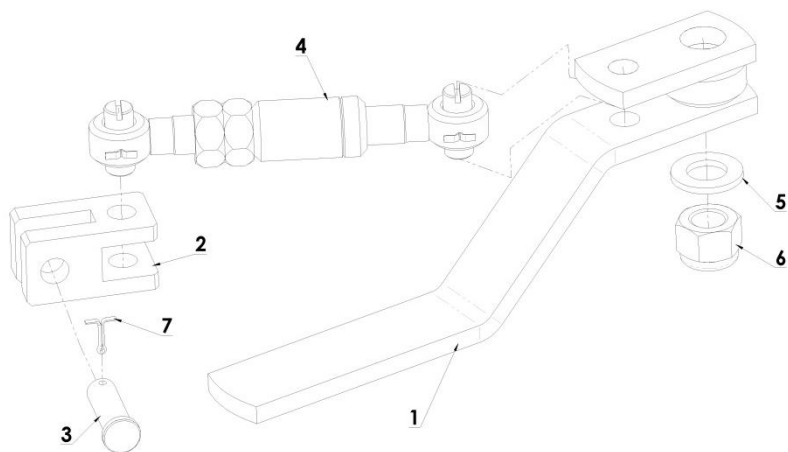



Table 12. Rear closure.

Position	Part name	Number	Amount
1	Rear lever	7104/00.25.200	1
2	Connector	7104/00.25.001	1
3	Swivel	7104/00.25.002	1
4	Closure flexible connector	7104/00.25.100	1
5	Washer 17	PN-85/M-82005	1
6	M16 Self-locking nut	PN-85/M-82175	1
7	S-Zn-3,2x18 Pin	PN-76/M-82001	1

# Closure flexible connector

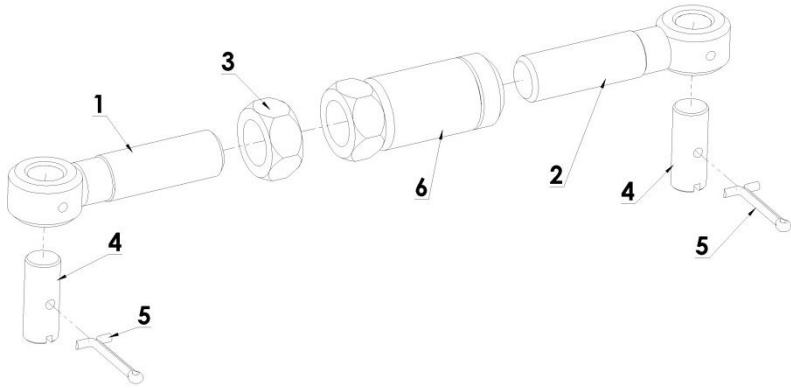

Table 13. Closure flexible connector

Position	Part name	Number	Amount
1	Right scroll eye bolt	7104/00.25.120	1
2	Left scroll eye bolt	7104/00.25.130	1
3	M16 Nut	PN86/M-82144	1
4	Swivel I	7104/00.25.101	2
5	S-ZN 3,2X32 Pin	PN-76/M-82001	2
6	Nut set	7104/00.25.110	1

# Walls set

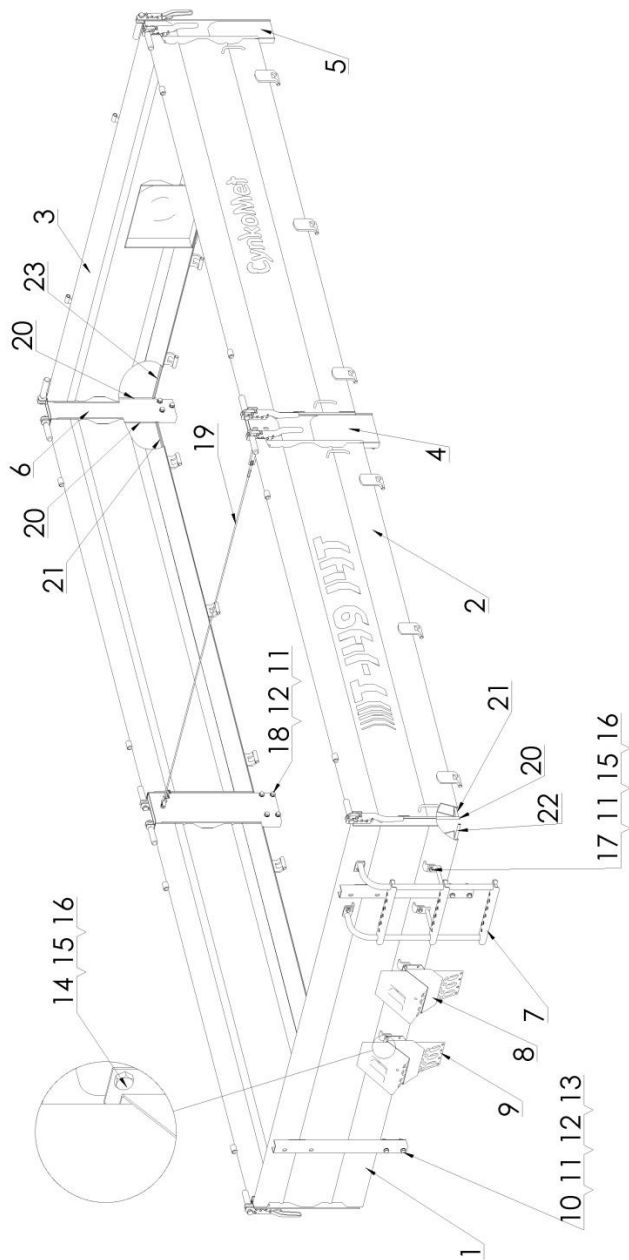

Table 14. Walls set

Position	Part name	Number	Amount
1	Front wall	7149/50.02.000	1
2	Side wall	7149/50.01.000	4
3	Rear wall	7149/50.03.000	1
4	Bottom center post	7149/50.04.000	2
5	Bottom left post	7149/50.05.000	1
6	Bottom right post	7149/50.06.000	1
7	Ladder II	7169/51.05.000	1
8	Wedge Handle G46	TK110.446.215	2
9	G46 Yellow wedge	TK2005	2
10	M12x70-8.8 Screw	PN-85/M-82101	4
11	Washer 13	PN-78/M-82005	26
12	Spring washer 12,2	PN-77/M-82008	20
13	M12 Nut	PN-86/M-82144	4
14	M8x20-8,8-B Screw	PN-85/M-82105	4
15	Spring washer 8,2	PN-77/M-82008	8
16	M8 Nut	PN-86/M-82144	8
17	M8x25-8.8 Screw	PN-85/M-82105	4
18	M12x35-8.8 Screw	PN-85/M-82105	14
19	Fastening spring	7149/00.09.000	1
20	Self-adhesive seal	10x6-SD-53	10
21	Self-adhesive seal	10x6-SD-53	4
22	Self-adhesive seal	10x6-SD-53	1
23	Self-adhesive seal	10x6-SD-53	1

# Rear wall

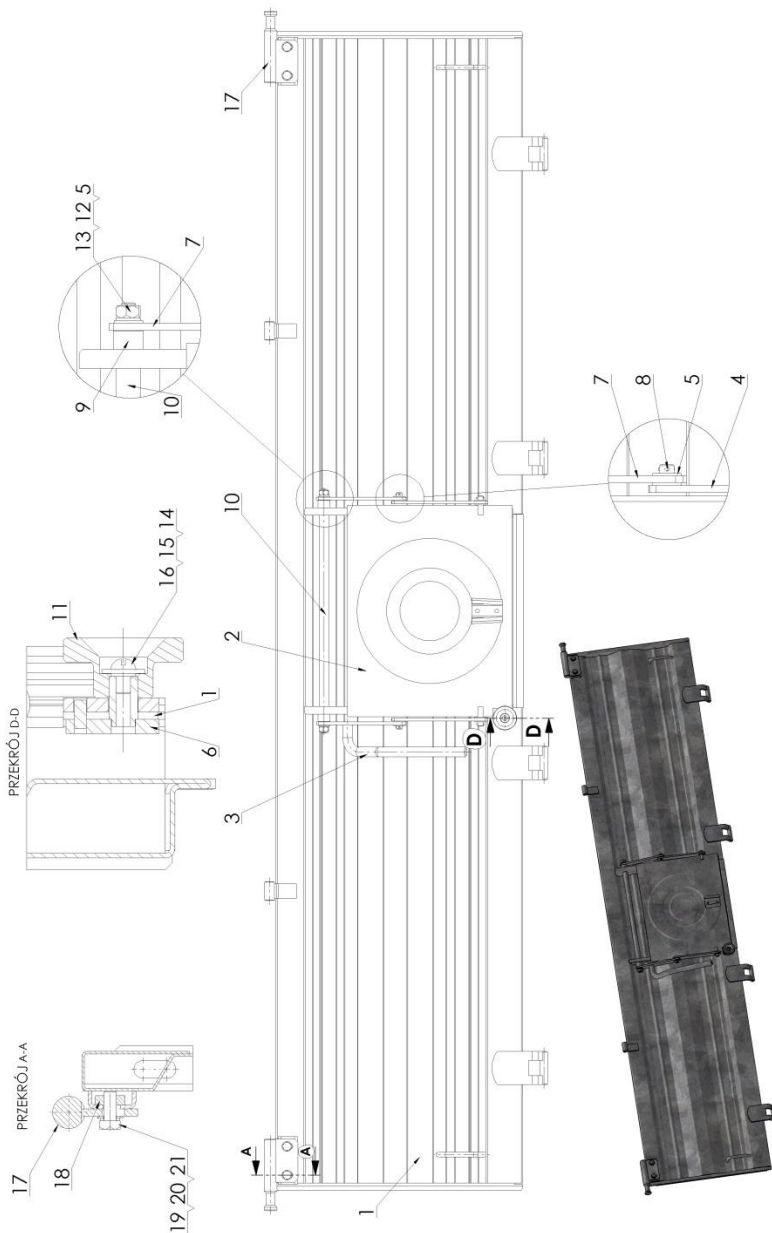

Table 15. Rear wall

Position	Part name	Number	Amount
1	Welded rear wall	7149/50.03.100	1
2	Slider set	7104/05.03.000	1
3	Lever set	7104/05.02.000	1
4	Flexible connector	7104/05.04.000	2
5	Washer 13	PN-78/M-82005	10
6	Plate set	7104/05.05.000	1
7	Arm	7104/05.00.003	1
8	S-Zn-3,2x18 pin	PN-76/M-82001	4
9	Sleeve	7104/05.00.004	2
10	Connector	7104/05.00.005	1
11	Nut	7104/05.00.006	1
12	Spring washer 12,2	PN-77/M-82008	2
13	M12 Nut	PN-86/M-82144	2
14	Washer 6,4	PN-77/M-82030	1
15	Washer 6.1	PN-77/M-82008	1
16	M6x10-5.8-B Screw	PN-85/M-82201	1
17	Hook set	7117/00.00.100	2
18	Plate	7117/00.00.004	2
19	Round washer 10,5	PN-78/M-82030	4
20	Spring washer 10.2	PN-77/M-82008	4
21	M10x25 Screw	PN-85/M-82105	4

# Extensions set

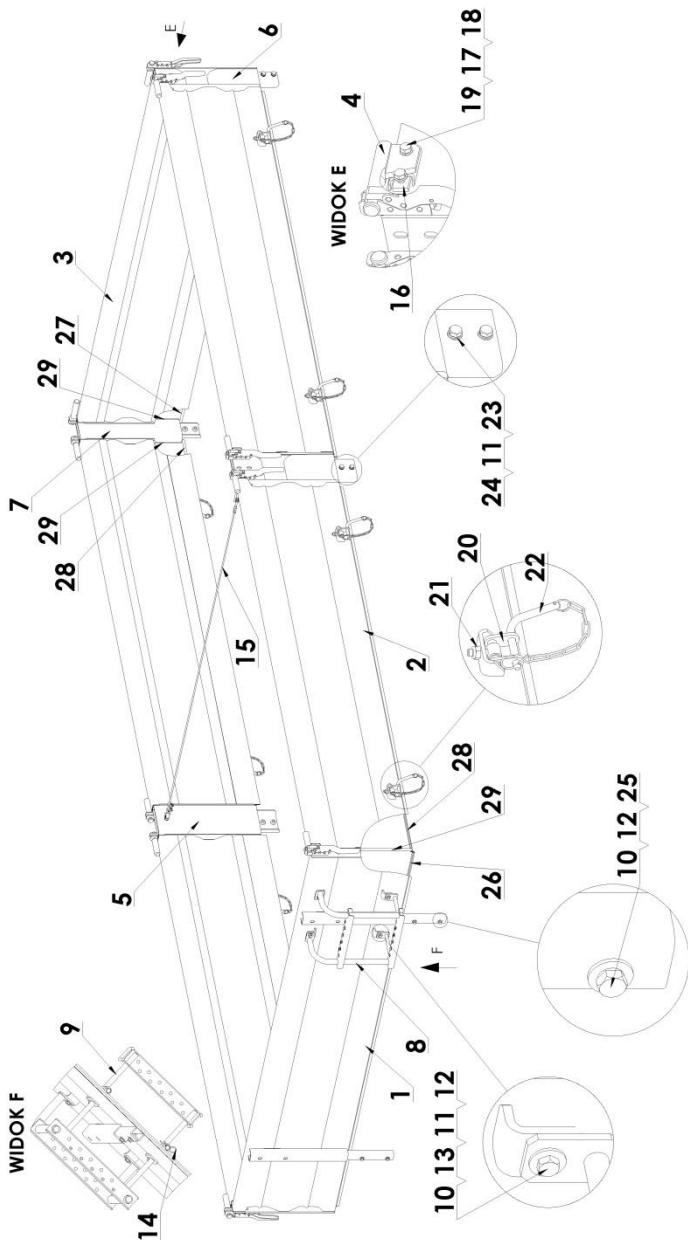



Table 16. Extensions set

Position	Part name	Number	Amount
1	Front extension	7149/51.02.000	1
2	Side extension	7149/51.01.000	4
3	Rear extension	7149/51.03.000	1
4	Hook set	7117/00.00.100	2
5	Upper center post	7149/51.04.000	2
6	Upper left post	7149/51.05.000	1
7	Upper right post	7149/51.06.000	1
8	Ladder I	7169/51.04.000	1
9	Foot	7104/00.15.000	1
10	M8x25-8.8 Screw	PN-85/M-82105	8
11	Washer 13	PN-78/M-82005	12
12	Spring washer 8,2	PN-77/M-82008	8
13	M8 Nut	PN-86/M-82144	4
14	B71 clip pin	BN-81/1902-04	1
15	Fastening spring	7149/00.09.000	1
16	Plate	7117/00.00.004	2
17	Round washer 10,5	PN-78/M-82030	4
18	Spring washer 10.2	PN-77/M-82008	4
19	M10x25 Screw	PN-85/M-82105	4
20	Side hinge	7104/00.00.100/5	10
21	M12 Self-locking nut	PN-85/M-82175	10
22	Cotter pin set	7104/00.00.400/5	10
23	Spring washer 12,2	PN-77/M-82008	10
24	M12x25 Screw	PN-85/M-82105	8
25	Round washer 8,5	PN-59/M-82030	4
26	Self-adhesive seal	10x6-SD-53	1
27	Self-adhesive seal	10x6-SD-53	1
28	Self-adhesive seal	10x6-SD-53	4
29	Self-adhesive seal	10x6-SD-53	10

# Center extensions set

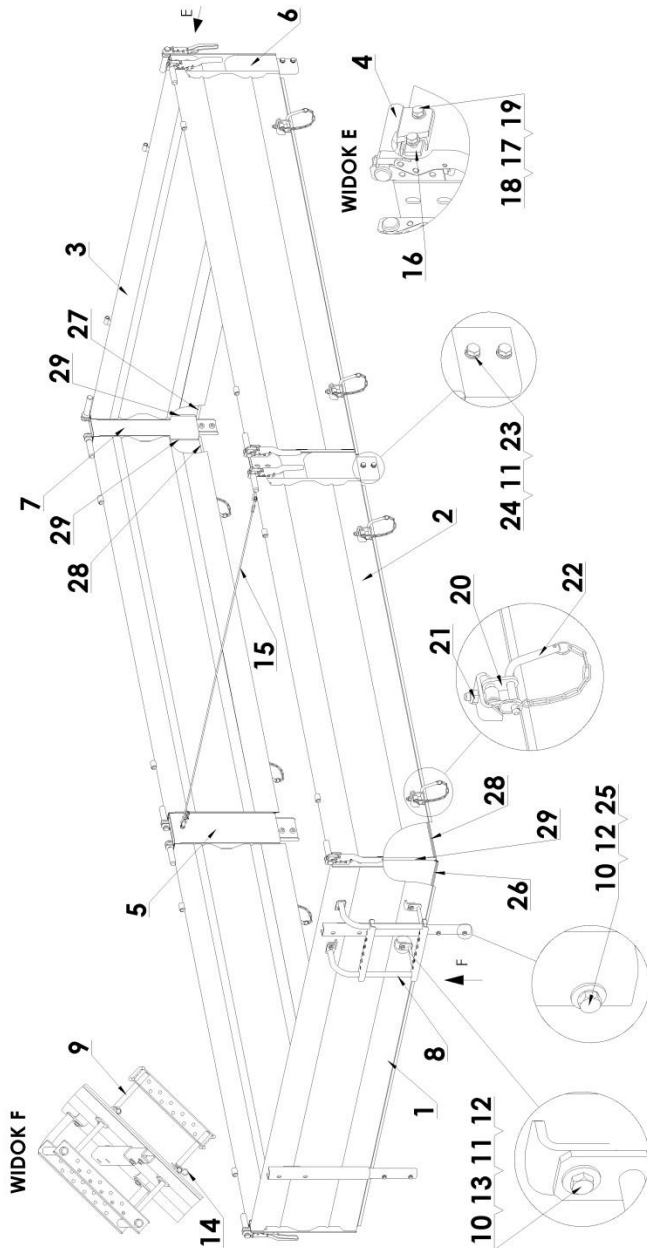

Table 17. Center extensions set

Position	Part name	Number	Amount
1	Front extension	7149/51.02.000	1
2	Middle side extension	7149/52.01.000	4
3	Middle rear extension	7149/52.03.000	1
4	Hook set	7117/00.00.100	2
5	Upper center post	7149/51.04.000	2
6	Upper left post	7149/51.05.000	1
7	Upper right post	7149/51.06.000	1
8	Ladder I	7169/51.04.000	1
9	Foot	7104/00.15.000	1
10	M8x25-8.8 Screw	PN-85/M-82105	8
11	Washer 13	PN-78/M-82005	12
12	Spring washer 8,2	PN-77/M-82008	8
13	M8 Nut	PN-86/M-82144	4
14	B71 clip pin	BN-81/1902-04	1
15	Fastening spring	7149/00.09.000	1
16	Plate	7117/00.00.004	2
17	Round washer 10,5	PN-78/M-82030	4
18	Spring washer 10.2	PN-77/M-82008	4
19	M10x25 Screw	PN-85/M-82105	4
20	Side hinge	7104/00.00.100/5	10
21	M12 Self-locking nut	PN-85/M-82175	10
22	Cotter pin set	7104/00.00.400/5	10
23	Spring washer 12,2	PN-77/M-82008	10
24	M12x25 Screw	PN-85/M-82105	8
25	Round washer 8,5	PN-59/M-82030	4
26	Self-adhesive seal	10x6-SD-53	1
27	Self-adhesive seal	10x6-SD-53	1
28	Self-adhesive seal	10x6-SD-53	4
29	Self-adhesive seal	10x6-SD-53	10

## Hydraulic installation

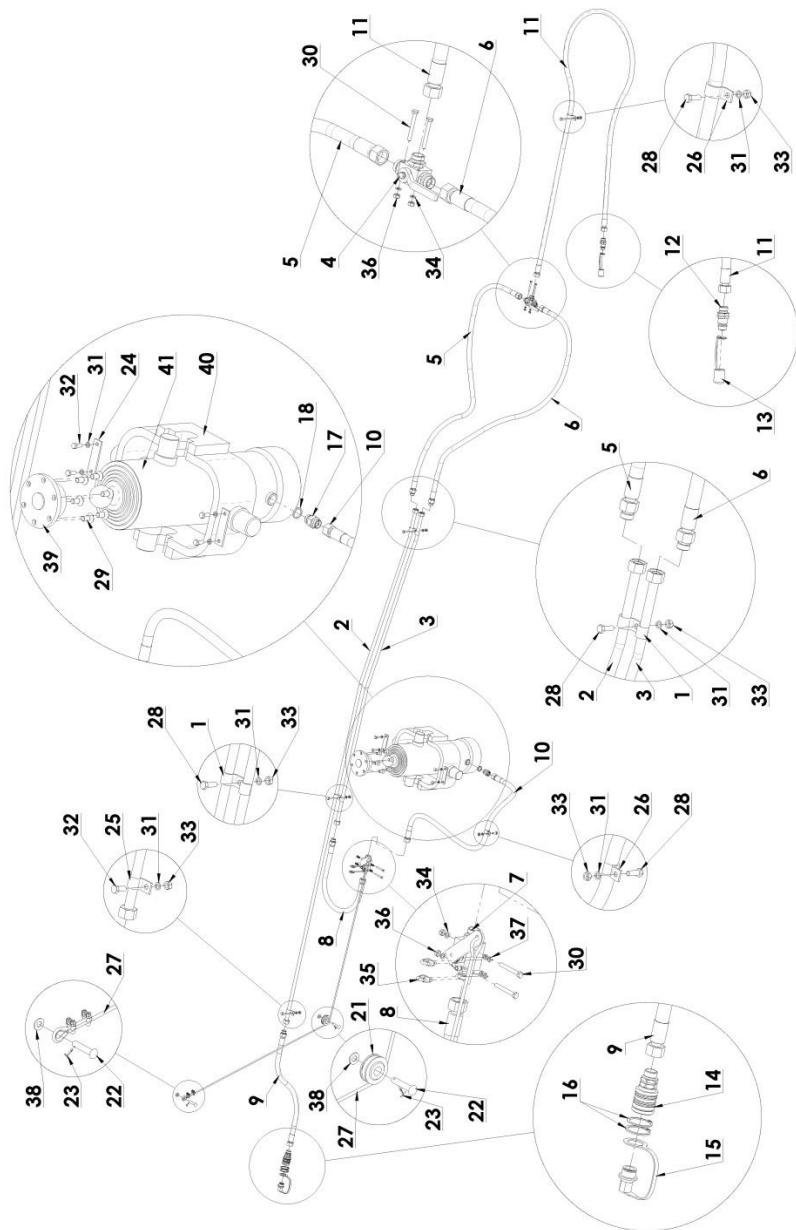

Table 18. Hydraulic installation

Position	Part name	Number	Amount
1	Clamp	7076/32.00.002	2
2	Tube	7149/15.00.001/2	1
3	Small tube	7149/15.00.003/1	1
4	Three-way valve	BK3-15L 131.123	1
5	AB-16-1400-13/13 Hose	BN-81/1903-01	1
6	AB-16-1400-13/13 Hose	BN-81/1903-01	1
7	Shut-off tipping valve	456-01-120 DN13-HBKH-15L	1
8	AB-16-700-13/13 Hose	BN-81/1903-01	1
9	AB-16-700-13/13 Hose	BN-81/1903-01	1
10	AA-16-1200-13/13 Hose	BN-81/1903-01	1
11	AA-16-3000-13/13 Hose	BN-81/1903-01	1
12	ISO-12,5 (16L) Plug cover	ISO 7241-A	1
13	ISO-12,5 Plug cover	ISO 7241-B	1
14	ISO-12,5 (16L) socket connector	ISO 7241-A	1
15	ISO-12,5 Socket cover	ISO 7241-B	1
16	Z40 retaining circlip ring	PN-81/M-85111	2
17	16-16/13 Simple connection body	PN-66/M-73144	1
18	Washer	7076/11.00.008	1
19	16-13 Cutting ring	PN-65/M-73137	4
20	16-13 Nut	PN-65/M-73139	4
21	Hand brake wheel	2208/09.00.006	1

# Hydraulic installation continued

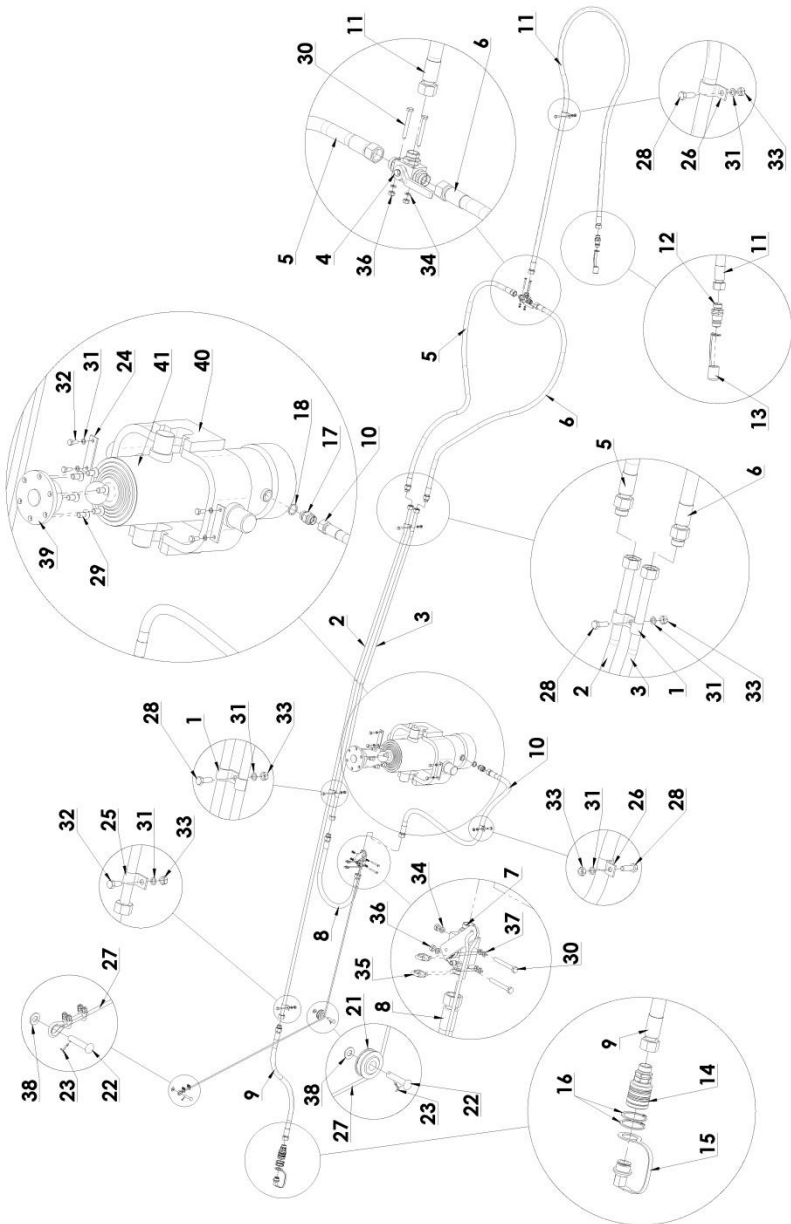

Table 18 continued Hydraulic installation

Position	Part name	Number	Amount
22	Special rivet	2213/07.00.004/0	2
23	S-Zn-2,5x18 Pin	PN-76/M-82001	2
24	Protection of the actuator	7104/11.00.004	2
25	Clamp II	7074/04.00.006	1
26	Hose hook	7074/04.00.007	2
27	String set	7104/58.06.000	1
28	M8x25-8.8 Screw	PN-85/M-82105	4
29	M12x25 Socket screw with a conical head	DIN 7991	6
30	M6x50 Screw	PN-85/M-82101	4
31	Spring washer 8,2	PN-77/M-82008	9
32	M8x20-8,8-B Screw	PN-85/M-82105	5
33	M8 Nut	PN-86/M-82144	5
34	Washer 6.1	PN-77/M-82008	4
35	Terminal clip 6,5	PN-73/M-80241	2
36	M6 Nut	PN-86/M-82144	4
37	M5 Nut	PN-86/M-82144	4
38	Washer 10	PN-78/M-82005	2
39	Bearing	ŁS-55-2	1
40	Actuator sling	ZS-145	1
41	Actuator	CT 145-5-1980	1

# Two-wire pneumatic installation

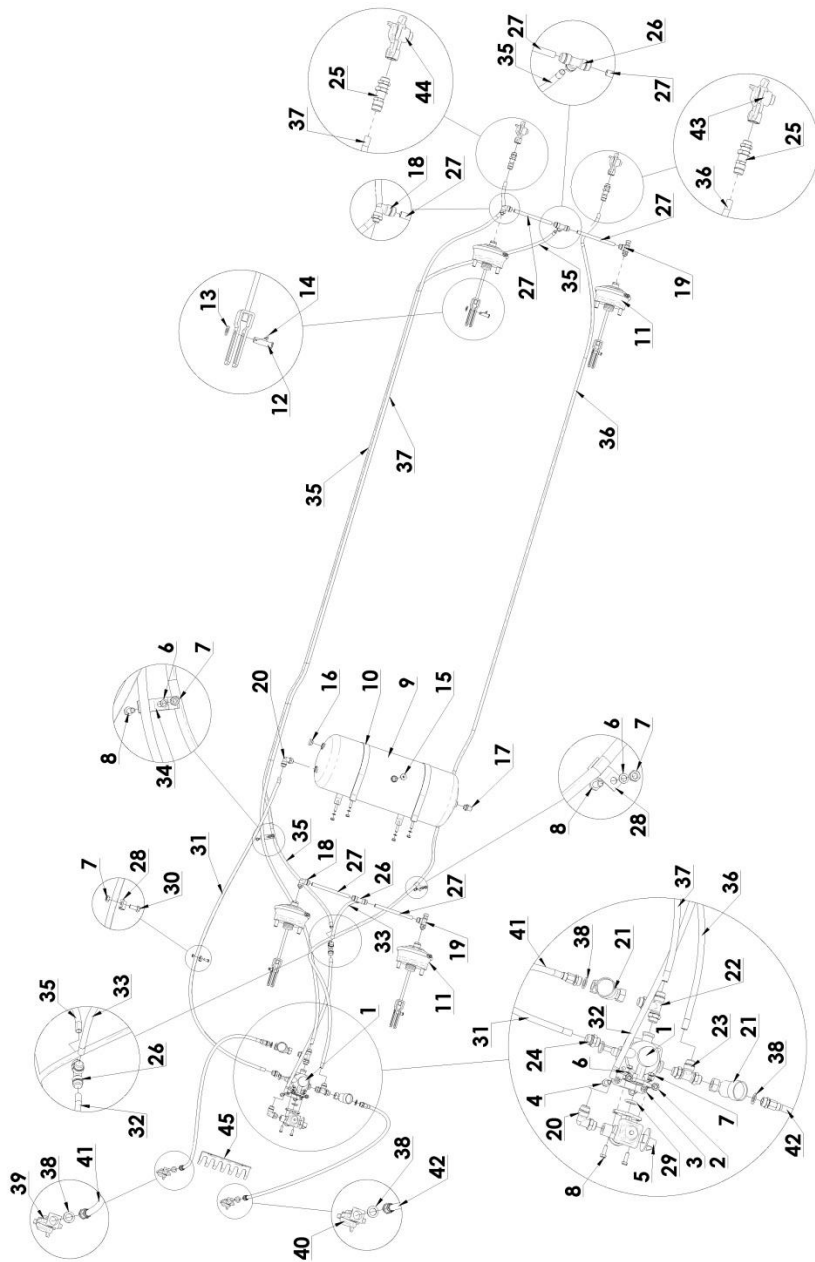
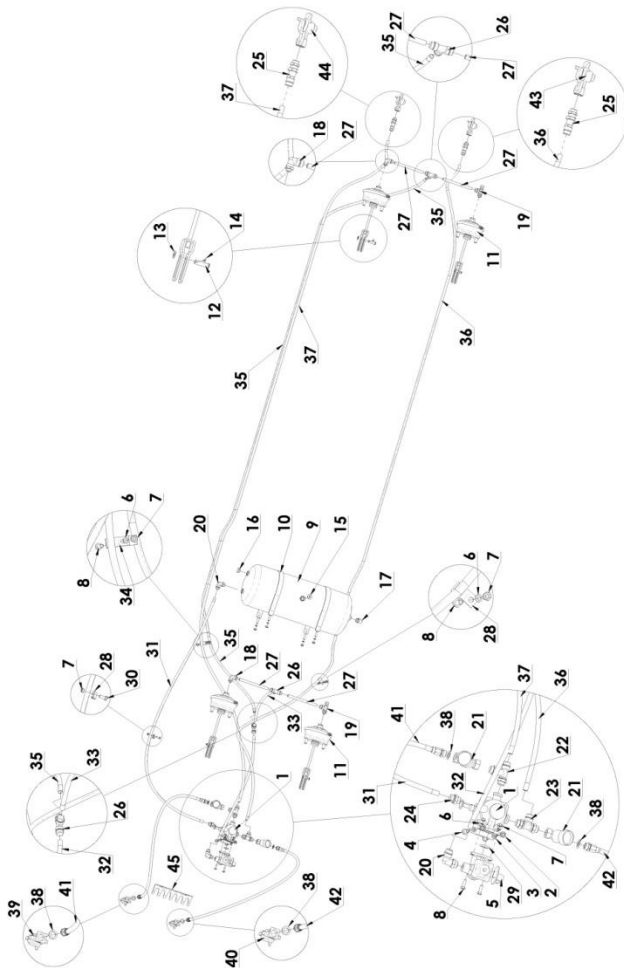



Table 19. Two-wire pneumatic installation

Position	Part name	Number	Amount
1	HZS-4 Control valve	44.12.010.0	1
2	M10 Nut	PN-86/M-82144	6
3	Spring washer 10.2	PN-77/M-82008	6
4	M10x30 8.8 Screw	PN-85/M-82105	2
5	Braking force regulator	61.11.013.0	1
6	Spring washer 8,2	PN-77/M-82008	4
7	M8 Nut	PN-86/M-82144	5
8	M8x25-8.8 Screw	PN-85/M-82105	4
9	40L Air tank	393.404.0	1
10	Tank clamp	7076/28.00.100	2
11	24" Diaphragm actuator	74.50.017.0	4
12	Pin	7105/13.00.001	4
13	Washer 13	PN-78/M-82005	4
14	S-Zn 3,2x25 Pin	PN-78/M-82001	4
15	ZS/M22 draining valve	S1110002003800	1
16	M22 plug	S1110038000000	1
17	ZŁW-HPM16/M22 Control connector	S1113301380000	1
18	15/M16 Three-way connector	S1110015350000	2
19	Three-way connector with a control valve HPM16/15/M16	S1113301153500	2
20	15/M22 L-shaped connector	S1110015380000	2
21	Inline filter	81.10.010.0	2
22	15/M22/M22 Three-way connector	S1110015383800	1
23	M22/15/M22 Three-way connector	S1110038153800	1
24	15/M22 Simple connector	S1110015003800	1

25	15/M22 bulkhead connector	S1116538004800	2
26	15/15/15 Three-way connector	S1110015151500	3



Two-wire pneumatic installation continued.

Table 19 continued Two-wire pneumatic installation.

Position	Part name	Number	Amount
27	Tecalan hose 15x1,5 L-200	7149/24.00.019	4
28	Clamp II	7074/04.00.006	2
29	22x5 sealing ring	PN-64/M-73093	1
30	M8x20-8,8-B Screw	PN-85/M-82105	1
31	15x1,5 L-1760 Tecalan hose	7149/24.00.020	1
32	15x1,5 L-920 Tecalan hose	7149/24.00.021	1
33	15x1,5 L-510 Tecalan Hose	7149/24.00.012	1
34	Clamp	7076/32.00.002	1
35	15x1,5 L-4265 Tecalan hose	7149/24.00.022	1
36	15x1,5 L-4920 Tecalan hose	7149/24.00.023	1
37	Tecalan hose 15x1,5 L-4900	7149/24.00.007	1
38	Metal Rubber Seal 1/2	U c1/2	4
39	A1 cable connector	87.10.020.0	1
40	A2 cable connector	87.10.030.0	1
41	Spiral yellow cable M22/M22 L-5000	L=5000z	1
42	M22/M22 L=5000 Red spiral cable	L=5000	1
43	B2 Cable connectors	87.15.030.0	1
44	B1 Cable connectors	87.15.020.0	1
45	Hydraulic hoses bracket	2264/00.00.002	1

# Handbrake.

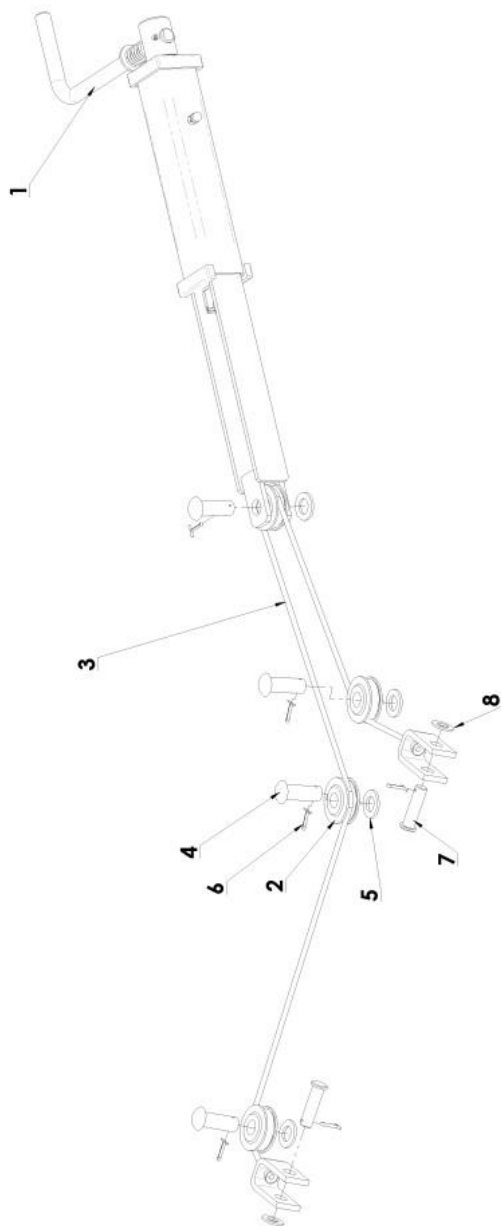

Table 20. Handbrake.

Position	Part name	Number	Amount
1	The handbrake mechanism	7149/24.10.000	1
2	Hand brake wheel	7110/16.00.001	4
3	Handbrake cable II set.	7149/24.09.000/ 1	1
4	Special rivet	2213/03.00.011/ 1	4
5	Washer 17	PN-85/M-82005	4
6	S-Zn 3,2x25 Pin	PN-78/M-82001	6
7	Bolt	7105/13.00.001	2
8	Washer 13	PN-78/M-82005	2

# The handbrake mechanism.

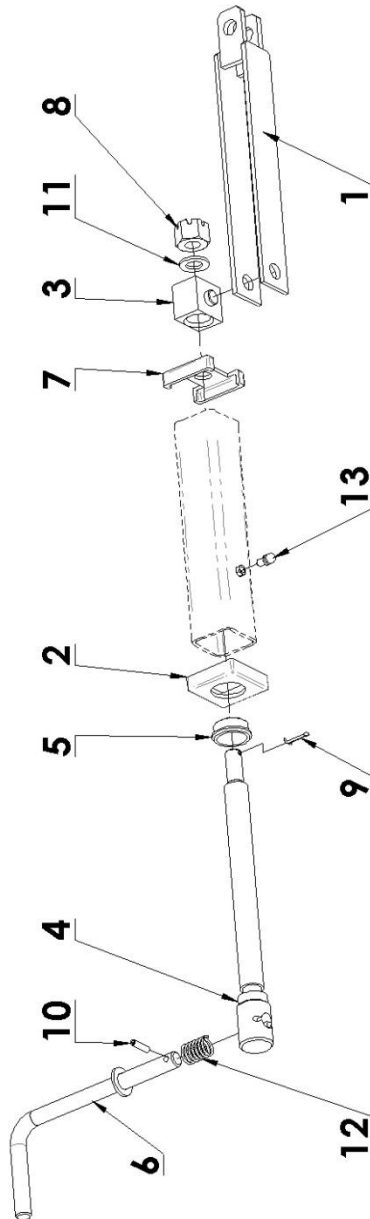

Table 21. The handbrake mechanism.

Position	Part name	Number	Amount
1	Glider set	7149/24.10.400/1	1
2	Washer I	7149/24.10.003/1	1
3	(Tr24X5) Nut	7149/24.10.002/1	1
4	Tr24x5 Screw	7149/24.10.001/1	1
5	Sleeve	7149/24.10.005	1
6	Crank set	7149/24.10.200	1
7	Cap II	7149/24.10.004/1	1
8	ZM-16 Castellated nut	PN-86/M-82148	1
9	S-Zn 4x32 Pin	PN-76/M-82001	1
10	Dowel pin 6x24	PN-89/M-85023	1
11	Washer 17	PN-85/M-82005	1
12	Spring	2219/02.04.114	1
13	M6 grease fitting	PN76/M-86002	1

# Toolbox

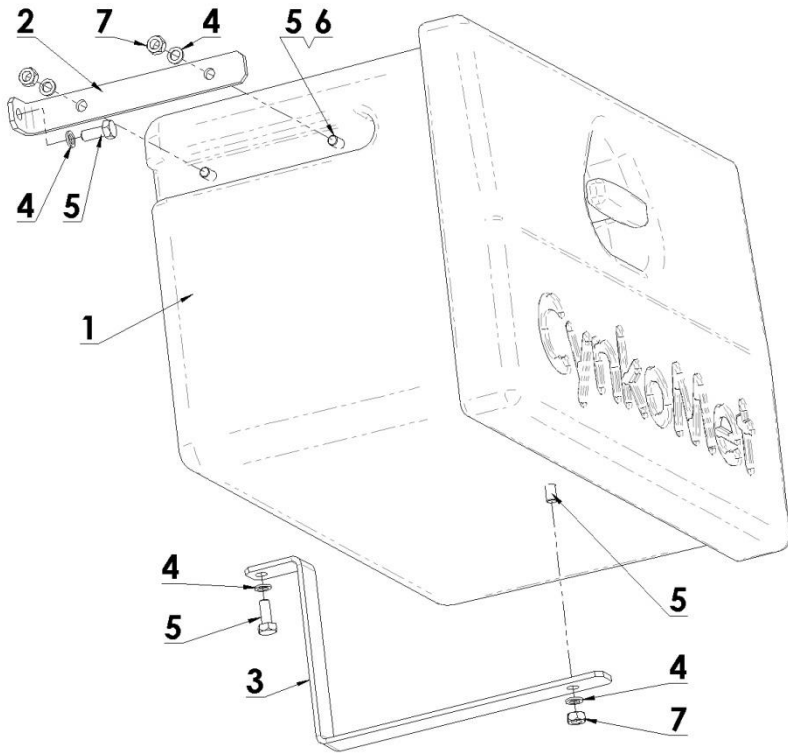



Table 22. Toolbox.

Position	Part name	Number	Amount
1	Toolbox	Stabilo 500-3	1
2	Box Brackets I	7149/00.00.021	2
3	Box Brackets II	7149/00.00.022	1
4	Spring washer 8,2	PN-77/M-82008	8
5	M8x20-8,8-B Screw	PN-85/M-82105	8
6	Round washer 8,5	PN-59/M-82030	5
7	M8 Nut	PN-86/M-82144	5

# Front platform

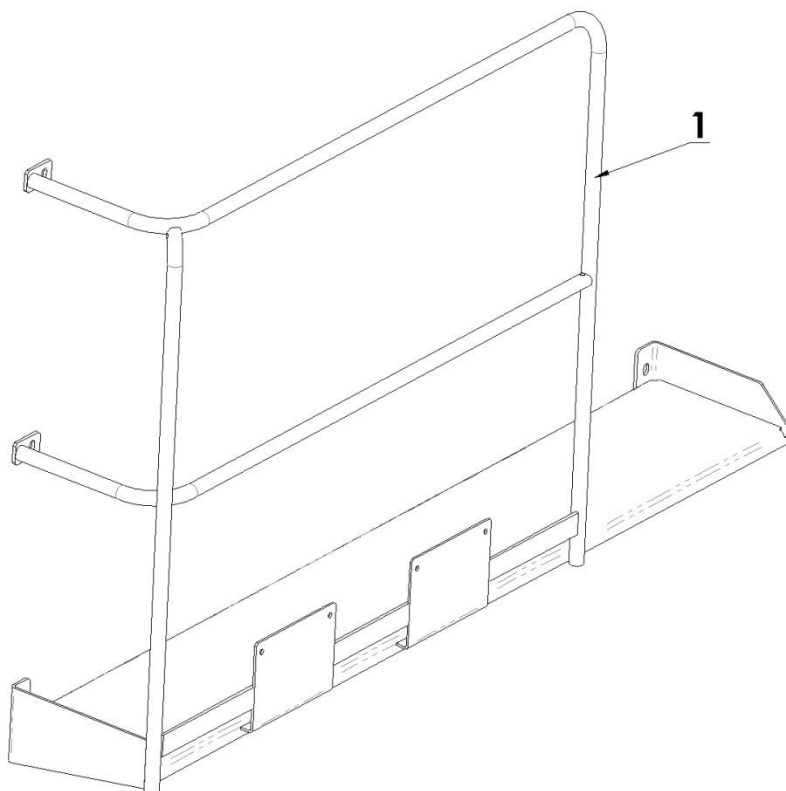

Table 23. Front platform.

Position	Part name	Number	Amount
1	Front platform	7149/00.19.000	1

# Tarpaulin frame

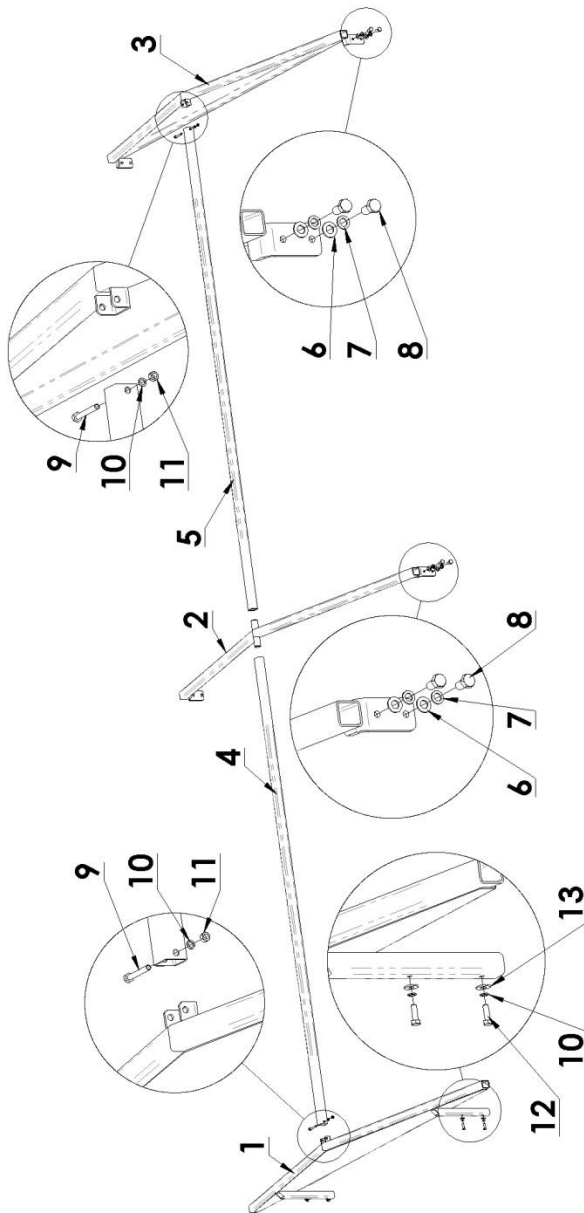

Table 24. Tarpaulin frame.

Position	Part name	Number	Amount
1	Front clamp	7149/35.01.000/ 1	1
2	Center clamp	7149/35.02.000	1
3	Rear clamp	7149/35.03.000	1
4	Front rack stringer	7149/35.00.001	1
5	Rear rack stringer	7149/35.00.002	1
6	Washer 13	PN-78/M-82005	8
7	Spring washer 12,2	PN-77/M-82008	8
8	M12x25 Screw	PN-85/M-82105	8
9	M8x60 Screw	PN-85/M-82101	2
10	Spring washer 8,2	PN-77/M-82008	6
11	M8 nut	PN-86/M-82144	2
12	M8x25-8.8 Screw	PN-85/M-82105	4
13	Round washer 8,5	PN-59/M-82030	4

## Tarpaulin

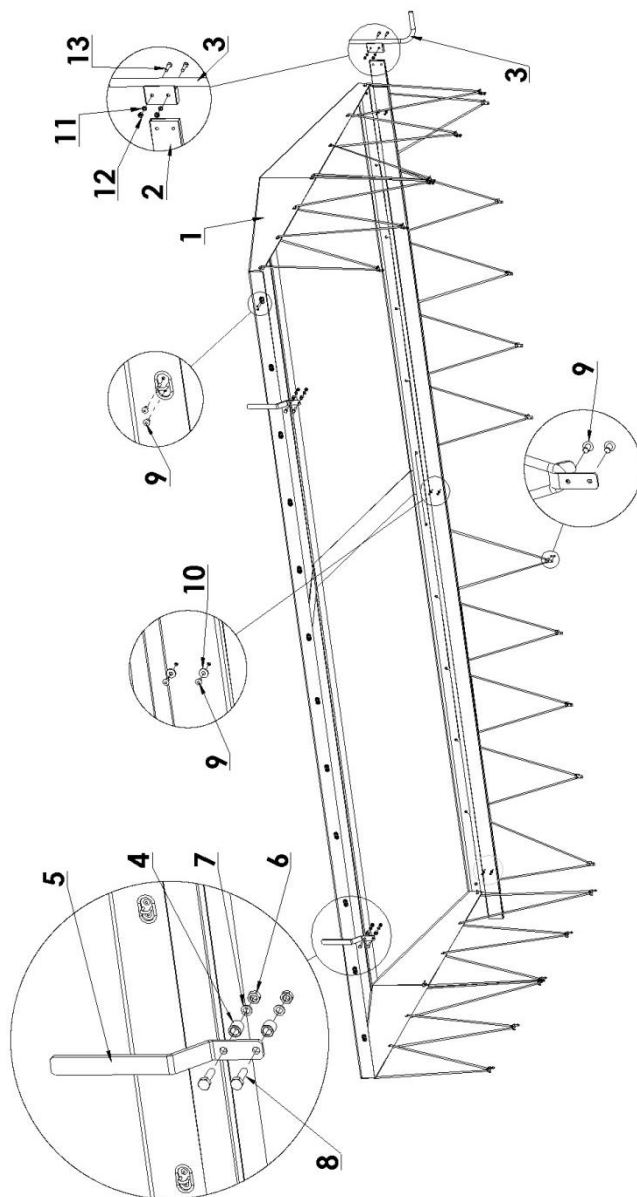

Table 24. Tarpaulin.

Position	Part name	Number	Amount
1	Tarpaulin	7149/34.01.000	1
2	90x18 L=5600 Slat	7149/34.00.001	1
3	Tarpaulin crank	7149/34.02.000	1
4	Sleeve	2213/00.00.027	4
5	Tarpaulin brackets	7149/34.00.002	2
6	M10 Nut	PN-86/M-82144	4
7	Spring washer 10.2	PN-77/M-82008	4
8	Screw M10x40 8.8	PN-85/M-82105	4
9	Blind rivet PAL / FE 5X8	PN83/M82971	74
10	Washer 5,5	PN59/M82030	6
11	Spring washer 8,2	PN-77/M-82008	2
12	M8 Nut	PN-86/M-82144	2
13	M8x35 screw	PN-85/M-82105	2

# Electrical installation

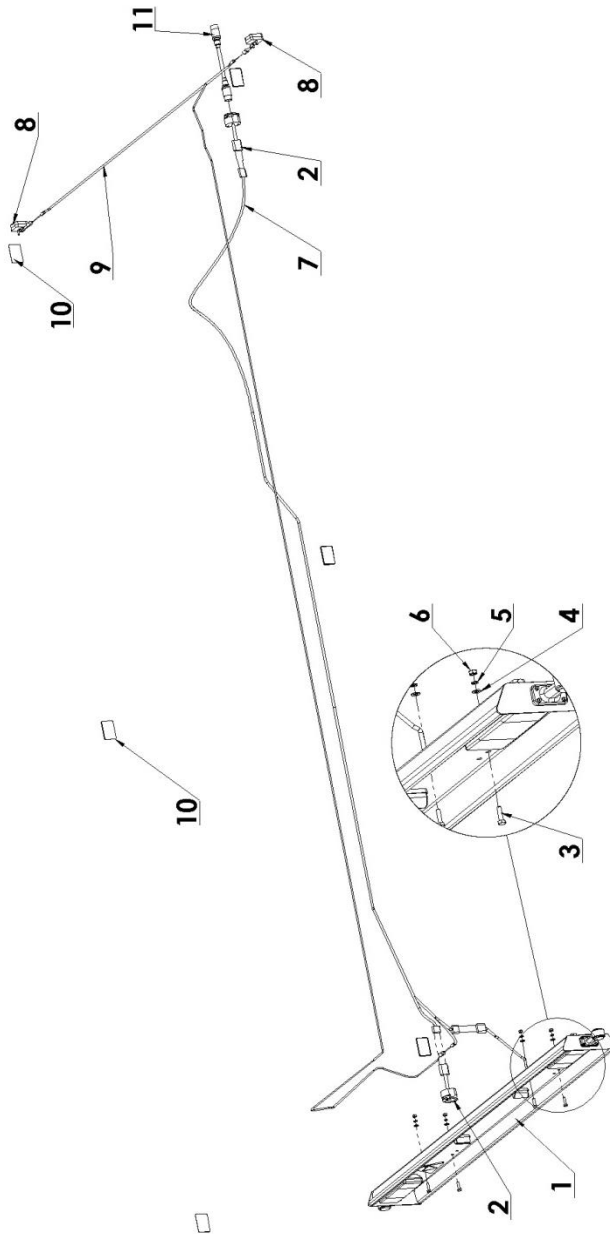



Table 25. Electrical installation.

Position	Part name	Number	Amount
1	Lighting hanger	7149/20.01.000/ 2	1
2	Socket	2235-04.10.004	2
3	M10x35 8.8 Nut	PN-85/M-82105	4
4	Flat washer 10,5	PN-78/M-82005	8
5	Spring washer 10.2	PN-77/M-82008	4
6	M10 nut	PN-86/M-82144	4
7	Central beam	7149/20.10.001	1
8	Front Clearance Lamp	7149/20.10.005	2
9	Headlights beam	7149/20.10.002	1
10	Reflective yellow device	UP-40R-ŻÓŁTE	6
11	Connecting cable	7104/57.10.004	1

# Hanger (protection) of the lighting.

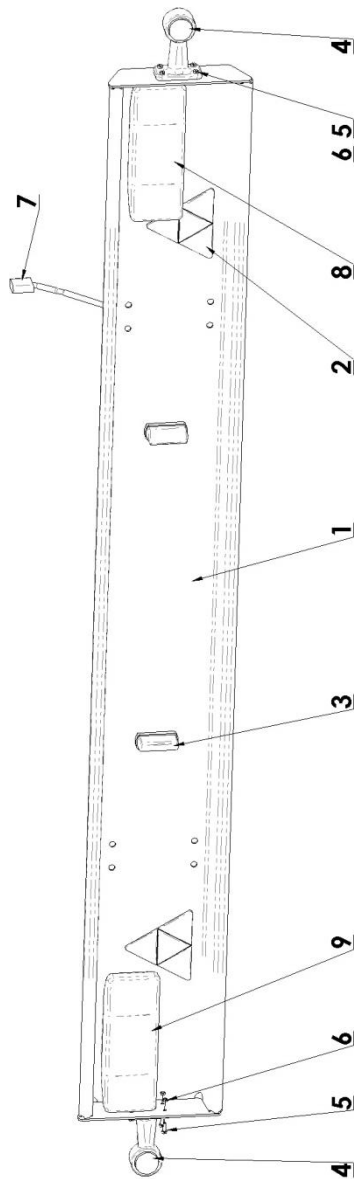

Table 26. Hanger (protection) of the lighting.

Position	Part name	Number	Amount
1	Light protection set	7149/20.01.100/ 1	1
2	Reflective triangular red device UT-150S	PN-90/S-73100	2
3	Lighting lamp of the registration plate	7149/20.10.004	2
4	Lampa obrysowa tylna	7149/20.10.006	2
5	M5x18 screw	PN-85/M-82215	8
6	M5 nut	PN-86/M-82144	8
7	Rear beam	7149/20.10.003	1
8	Right rear assembly light	7149/20.10.007	1
9	Left rear assembly light	7149/20.10.008	1

