

# TRAILER T-169/2

TECHNICAL SPECIFICATIONS | EQUIPMENT



 **HOMOLOGATION  
EUROPEAN**



Year of model 2022

version.1.2022

**CynkoMet**<sup>®</sup>  
Czarna Białostocka

<b>TECHNICAL SPECIFICATIONS</b>	
Type/version/variant	T-1/421/21
Technically (design) permissible total weight rating	8,400 kg
Gross vehicle weight rating	8,400 kg
Load capacity	~6,200 kg*
Kerb weight (without wall extensions)	~2,200 kg*
Length	6190 mm
Width	2300 mm
Height without extension	~1630 mm
Height with extension (EXTENSIONS IN STANDARD VERSION)	~2130 mm
Length of cargo box interior	4020 mm
Width of cargo box interior front/rear	2070/2120 mm
Box wall height	500 mm
Loading surface	8.4m <sup>2</sup>
cargo capacity	4.4 m <sup>3</sup>
Height of floor above ground	~1130 mm
Tire size	11.5/80-15.3 - 12
Floor/wall sheet thickness	4/2.5 mm
Track of wheels	1700 mm
Wheelbase	2700 mm
Drawbar coupling height – min.	540 mm
Drawbar coupling height – max.	840 mm
Coupling height of rear hitch (optional)	520 mm
Transport/working speed	30 km/h
Suspension	parabolic springs
Class of cooperating tractor	min. 60 HP
Tipping angle of the cargo box (backward / sideways)	45/50
Tipping system	three-way

\* - unladen weight and loading capacity may differ depending on the trailer's equipment

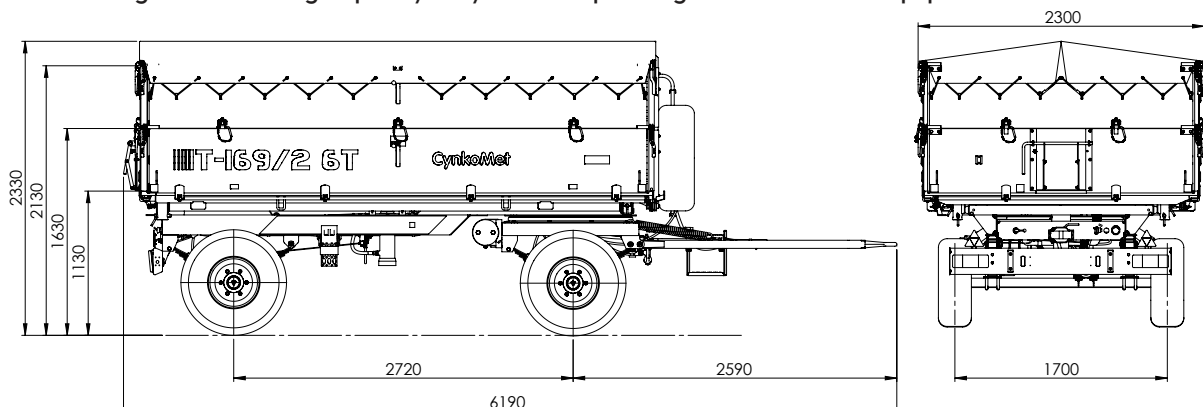

## STANDARD MACHINE EQUIPMENT

Wall height 500 mm with thickness 2.5 mm, hot-galvanized

New 11.5/80-15.3 wheels

Axles from renowned ADR company, homologated (EU 2015/68). Bar cross-section is square, 80 mm, brake size 300x90 309E, 6 M18x1.5 pins

Central bolt-locking of walls (bottom sideboards)

Exterior ladder and steps inside cargo box - hot-galvanized - with anti-skid steps facilitating access to cargo box

Two wheel chocks placed in galvanized pockets

Telescopic actuator with articulated suspensions, four-level with 1,300 mm pitch. Useful force at fourth level with diameter 105mm, at nominal pressure 16MPa = 138kN (~14T)

Tipping installation protected against excessive box inclination by cut-off valve

Maintenance support of cargo box, hot-galvanized

Frame of cargo box fully hot-galvanized.

Main stringers of cargo box frame made of metallurgical 160 channel sections

Cargo box floor with riveted and bolted sheets with a thickness of 4 mm

Hot-dip galvanized bottom frame (protection of the structure on the exterior and interior of profiles), stringers of the frame made of metallurgical 160 and 140 channel sections, additionally closed by 5 mm sheet

12V lighting, homologated, rear bulb lamps, LED perimeter lighting, rear socket for connection to second trailer

Side wall links

Hydraulic tipping installation of cargo box made of galvanized steel tubes and flexible hoses

Rear hydraulic output to second trailer

Hydraulic connectors to tractor, type ISO 7241-1 DN 12.5

Lighting installation connector cable with 7PIN 12V plug

Homologated, double-circuit, pneumatic brake system with automatic braking force adjustment from HALDEX, with output for second trailer.

Parking handbrake with crank

Two-component chemosetting paint materials with high durability and UV resistance

Triangular drawbar with adjustable support spring, with 40 mm eye, homologated according to Regulation 55UN ECE

Grain chute, hot-galvanized, with blockade in the rear wall

*All of our agricultural machines are designed and tested by our design team using the latest available tools. Manufacturing is performed with the greatest diligence and in adherence to rigorous quality standards.*

<b>OPTIONAL MACHINE EQUIPMENT</b>
<b>Structural elements</b>
Spare wheel hanger, hot-galvanized
Hot-galvanized tarpaulin frame made of 40x40x3 closed profiles
Hot-galvanized 500 mm wall extensions, thickness 2.5 mm
Chute for precise tipping, hot-galvanized
Hot-galvanized work platform
Side underrun guards
<b>Installations</b>
Full LED lighting
Homologated, hydraulic double-circuit brake system with automatic braking force adjustment
<b>Driving system</b>
Surcharge for 14/65 - 16 wheels
14/65-16 spare wheel
11.5/80-15.3 spare wheel
<b>Other equipment</b>
Drawbar eye 50mm
Roll-up tarpaulin
Laced tarpaulin
Warning triangle (sign distinguishing slow-moving vehicle)
Hydraulic quick-coupler with pressure neutralizer in hose
Set of side (bicycle) guards
DUPLEX - painted set of walls
DUPLEX - painted set of extensions

The data and photographs given in the catalog are for illustrative purposes only. This document and the information it contains, including prices, do not constitute a commercial offer within the meaning of art. 66 of the Civil Code. This information may be subject to change as products are continuously improved. The manufacturer reserves the right to change a product's characteristics at any time. Products' specifications may change without notice.



**HOT-  
GALVANIZED CONSTRUCTION**