

CynkoMet Sp. z o.o.
ul. Fabryczna 7W
16-020 Czarna Białostocka
phone (085) 710 24 56

“DZIK” manure mini-spreader

N-200

INSTRUCTIONS FOR USE AND OPERATION

Identification of the machine

Symbol/Type N-200

Serial number:.....

The serial number is stamped on the rating plate and on the beam of the drawbar on the left side of the spreader. The rating plate is riveted to the beam of the drawbar on the left side.

When buying the machine, check the conformity of the serial numbers stamped on the spreader with the serial number written in the warranty card, in the sales documents and in the instruction manual.

NOTE!

The manufacturer reserves the right to introduce, in the manufactured machines, structural alterations facilitating servicing and improving the quality of their work. The information on significant design changes are communicated to the user by means of enclosed information (annexes).

Comments and observations about the design and operation of the machine should be sent to the manufacturer. This information will allow objective evaluation of the machine, and serve as guidelines in their further modernization.

Before the operation, the user should be familiar with this manual and follow all recommendations. This will ensure safe maintenance and trouble-free operation of the machine.

If the information contained in the manual will prove to be not fully understood, it is advisable to seek help at the sales point in which the machine was purchased or go directly to the Manufacturer.

Manufacturer's Address:

CynkoMet Sp. z o.o.

ul. Fabryczna 7W

16-020 Czarna Białostocka

phone . (085) 710 24 56

**INSTRUCTIONS FOR USE AND SERVICE CONSTITUTES BASIC EQUIPMENT
OF THE MACHINE!**

The machine is designed in accordance with the applicable standards, documents and legal regulations currently in force.

DETERMINATION OF DIRECTIONS IN THE MANUAL

Left side - side to the left hand of the observer facing in the direction of travel of the machine forward.

Right side - the right-hand side of the observer facing in the direction of travel of the machine forward.

EC DECLARATION OF CONFORMITY

CynkoMet Sp. z o.o.

16-020 Czarna Białostocka ul. Fabryczna 7W Polska

Acting as the manufacturer

I declare with full responsibility that the machine:

MANURE SPREADER

TYPE / MODEL: N-200

YEAR OF PRODUCTION:

SERIAL NUMBER:

BRIEF DESCRIPTION OF THE MACHINE AND ITS FUNCTIONS:

The mini-spreader is a universal machine intended for spreading of manure, compost and cut grass. The spreader consists of a box, drawbar, interior wall and adapter. The rotating shafts of the adapter on the mini-spreader are powered by a mechanism transmitting torque from the driving wheels. The mini-spreader is adapted for coupling to ATVs or smaller tractors as well as to grass mowing tractors.

To which this declaration relates complies with the requirements:

- Directive 2006/42 / EC of the European Parliament and the Council of 17 May 2006 on machinery, and amending Directive 95/16 / EC (OJ L157 of 09.06.2006, pages 24-86)
- Regulations of the Minister of Economy of 21 October 2008 on essential requirements for machines (Journal of Laws of 2008, no. 199, item 1228)

For the conformity evaluation, the following harmonized standards have been used:

- PN-EN ISO 4254-1 Farm Equipment - Safety - Part 1: General requirements of 2014.
- PN-EN 690 Agricultural machinery – Manure spreaders – Safety
- PN-ISO 11684:1998P Tractors, machinery for agriculture and forestry, moto tools - Safety signs and pictograms of threats - General provisions of 1998.
- PN-EN ISO 12100-1:2012 Safety of machinery - General principles for design-Risk Assessment and reducing the risk of 2012.
- PN-EN ISO 13857:2010 - Safety of machinery - Safety distances preventing reaching of the upper and lower limbs into dangerous areas of 2010.

Person authorized to prepare technical documentation:
Head of the Designing and Process Engineering Department
Address: Fabryczna 7, 16-020 Czarna Białostocka, Poland

THE DECLARATION LOSES ITS VALIDITY, IF THE MACHINE IS CHANGED OR REBUILT WITHOUT CONSENT OF THE PRODUCER.

Czarna Białostocka
Place and date of declaration

Identity and signature of the person
authorized to issue the declaration

Table of contents

1. Introduction	6
1.1 Identification of the machine.....	7
2. Purpose of the mini-spreader	8
3. Safety in use	10
3.1 General safety and accident prevention regulations.....	10
3.2 Attaching and detaching the machine to the tractor.....	12
3.3 Tires on driving wheels.....	12
3.4 Adapter drive system.....	12
3.5 Maintenance.....	13
3.6 The principles of movement on public roads.....	13
3.7 Description of residual risk.....	14
3.8 Residual risk assessment.....	15
3.9 Information and warning stickers.....	16
3.10 Technical characteristics.....	20
4. Information regarding use	20
4.2 Description of construction and operation.....	20
4.2.1 General description.....	20
4.2.2 Lower frame / drawbar.....	23
4.2.4 Adapter.....	25
4.2.5 Drives.....	26
4.3 Rules of proper use of the spreader.....	27
4.3.1 Preparation before running for the first time.....	27
4.3.2 Preparation for the spreader's work.....	31
4.3.3 Loading the spreader.....	31
4.3.4 Coupling and decoupling with the drawing machine.....	32
4.3.5 Loading the cargo box.....	33
4.3.6 Load transport.....	35

4. Technical Support **37**

 4.1 Adapter maintenance..... 38

 4.2 Conveyor feed adjustment. 39

 4.3 Adapter drive control. 39

 4.4 Lubrication..... 41

 4.6 Storage and maintenance. 45

 4.7 Troubleshooting. 46

5. Transport**48**

6. Spreader cassation **49**

7. Guarantee **50**

1. Introduction

This manual describes the basic principles of safe use and operation of manure mini-spreader.



NOTE!

NOTE!

Before using the mini-spreader, you should carefully read the contents of the manual. Before each running of the mini-spreader, it must be checked in terms of operational safety.

If the information contained herein will prove to be not fully understood, seek help from the manufacturer of the machine or the sales point where it was purchased.

Particularly important information and recommendations, the observance of which is absolutely necessary in the text are highlighted in bold or preceded by the word „CAUTION!“.

Information, descriptions of danger and precautions as well as commands and orders "related to the safety of use are highlighted in the manual with a sign  and also mentioned in the chapter "SAFETY OF USE".

	<p>NOTE!</p> <p>The operating instructions must absolutely be passed at the moment of delivering the machine to another user, allowing him to get acquainted with its content. It is recommended that the transfer of the instruction is done against a confirmation.</p>
---	--

NOTE!

NOTE!

The operating instructions must absolutely be passed at the moment of delivering the machine to another user, allowing him to get acquainted with its content. It is recommended that the transfer of the instruction is done against a confirmation.

1.1 Identification of the machine

The manure mini-spreader is marked with the use of a nameplate (1) and a serial number (2). The serial number is found on the front wall of the cargo box, and the rating plate is also found on the front wall of the cargo box.

When buying the mini-spreader, check the compatibility of the serial numbers on the machine with the number written in the WARRANTY CARD , in the sales documents and in the USER'S MANUAL.

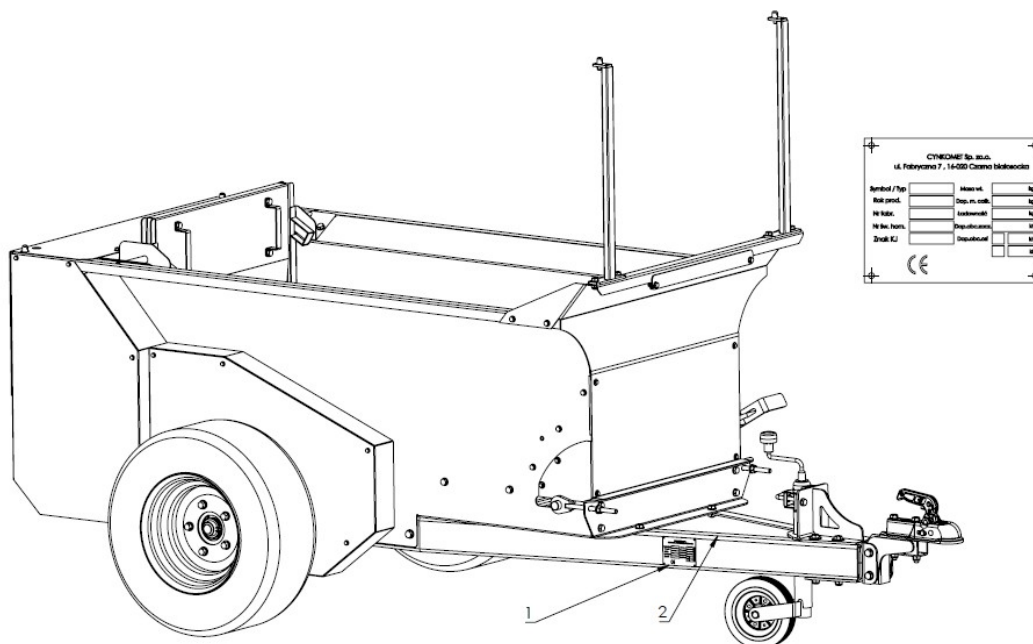



Figure 1. Location of the nameplate and issue of the serial number

1 - rating plate, 2 - serial number

	<p>NOTE!</p> <p>It is forbidden to use the spreader when the nameplate is illegible or has been removed from the machine.</p>
---	--

NOTE!

NOTE!

It is forbidden to use the spreader when the nameplate is illegible or has been removed from the machine.

2. Purpose of the mini-spreader

The mini-spreader is a universal machine intended for spreading of manure, compost and cut grass. After the adapter is dismounted, it can also serve as a trailer for works on a farm or property. The adapter, with two horizontal shafts to which the blades are welded, makes possible precise spreading of the material loaded onto the mini-spreader. The machine is also equipped with an interior wall that prevents the cargo from spilling while driving. The wall is raised and lowered manually. The spreader consists of a box, drawbar, interior wall and adapter. The rotating shafts of the adapter on the mini-spreader are powered by a mechanism transmitting torque from the driving wheels. Drives are engaged by means of a lever found on the mini-spreader's side wall.

Failure to follow the transport and loading of goods specifications described by the Manufacturer will void the warranty service and is regarded as use of the machine incompatibly with its purpose.

The mini-spreader is adapted for coupling to ATVs or smaller tractors as well as to grass mowing tractors. The hitch in the machines mentioned above should be adapted for a BC-1200M hitching head (specifications $D=11.3\text{kN}$, $S=120\text{ kg}$, $\text{DMC} = 1200\text{ kg}$).

The spreader IS NOT SUITABLE and cannot be used to transport people and / or animals and other materials identified in the following pages.

 <p>NOTE!</p>	<p>NOTE!</p> <p>The spreader must not be incompatibly with its purpose, and in particular:</p> <ul style="list-style-type: none">• for transporting people and animals,• for transporting bulk hazardous toxic materials when there is a possibility of causing environmental contamination,• to transport machinery and equipment,• spreading manure, peat, cut grass, where in those materials there are stones, pieces of wood or other solid materials that can damage the adapter and threaten the safety of users and bystanders,• to carry stones, gravel and other building materials,• to carry gravel, sand, salt, etc.
--	---

Use in accordance with the product's destination also includes all activities related to correct and safe operation and maintenance of the machine. Therefore, the user is obliged to:

- Read the content of the USER'S MANUAL of the spreader and the WARRANTY CARD and adhere to the recommendations contained in these documents.
- Comply with the established maintenance plans and regulations.
- Comply with general safety regulations while working.
- Prevent accidents.
- Read the instructions for operating the agricultural tractor and comply with its recommendations, in combination with the spreader.

The spreader can be handled and operated only by persons of full age who:

- Are familiar with ALL THE CONTENT of the mini-spreader's manual.
- Have the required licenses and experience for driving a quad, tractor, mower.

 <p>NOTE!</p>	<p>NOTE!</p> <p>The operation and exploitation of the machine not in accordance with the Instruction Manual releases the Manufacturer from liability for the consequences resulting from non-compliance with the provisions contained therein. At the same time, it causes a loss of warranty.</p>
--	---

 <p>NOTE!</p>	<p>NOTE!</p> <p>The manufacturer is not responsible for changes made by the user in the design of the spreader, and such changes will void the warranty.</p>
--	---

3. Safety in use

3.1 General safety and accident prevention regulations

- Before using the spreader, you should carefully read the contents of the manual. During operation, observe all instructions contained in the manual.
- Before every start-up, the spreader must be checked for safety of operation (completeness of all guards, fastening of all screws (table 6)), whether there are cracks or visible damage on the structure, chain tension "not too loose" is checked by lifting the chain up by the central strip (the space between the floor panel and strip should be about 3 cm), and the condition of the ball hitch).
- Climbing onto the spreader is prohibited.
- The spreader can be coupled to vehicles equipped with a ball hitch designed for coupling with the BC-1200M hitch. It is strictly prohibited to tow the spreader with a passenger car. Pay attention to the warnings in places of crushing and shearing when starting the machine and all the pictograms placed on the spreader.
- The speed of driving must always be adapted to the environmental conditions. Avoid travel over ditches and avoid sudden turns.
- When coupling and decoupling the mini-spreader to/from the driving

vehicle, you must take special caution.

- Exceeding the permissible load can cause accidents and damage to the machine.
- When cornering, you should take into account the inertia of the machine.
- Before you start, check if the spreader has any loose parts.
- Within additional elements which are force operated (e.g. by hand), there are places of crushing and shearing.
- Only remove disturbances in the spreader's operation when the machine is at a complete standstill.
- The permissible transport speed 15 km / h cannot be exceeded.
- It is forbidden to transport people or animals on the spreader.
- It is forbidden to enter the cargo box while the machine is running.
- Decoupling of the mini-spreader from the towing vehicle is prohibited while the engine is running.
- Modifications can be made only with the permission of the manufacturer. The basic condition for safety are original spare parts and components. Using other parts may result in exclusion of liability of the manufacturer for resulting consequences.
- Careless operation and use of the spreader can injure the operator or third parties.
- It is prohibited for persons not licensed to drive the mini-spreader's towing vehicle to use the machine.
- It is forbidden to use the spreader in non-compliance to its purposes. Prior to every use of the spreader, check its technical condition, especially the condition of the coupling system, drive system, and guards.
- The machine is marked with information and warning inscriptions in the form of stickers as specified in Table 1. The user is obliged to constantly take care of the readability of signs and warning symbols on the machine. In the event of damage or destruction replace them with new ones.
- Labels with inscriptions and symbols are available from the manufacturer.

3.2 Attaching and detaching the machine to the tractor

- Before attaching the mini-spreader, make sure that the driving vehicle and spreader are technically efficient.
- When coupling the spreader, use only a ball hitch. After completion of the machine coupling, check the security of the hitch. Be very careful when you connect the machine.
- During coupling of the mini-spreader, the driving machine and engine must be switched off, and the key should be removed from the ignition switch.
- Next, the mini-spreader (without cargo) should be pulled to the driving vehicle manually and coupled to the ball hitch. The coupling should be checked thoroughly.
- After coupling the mini-spreader, raise the adjustable support to its maximum height, so that it does not come into contact with the floor during driving, and lock it into place. If the support comes into contact with the floor during driving, it may be damaged, and in extreme cases, even damage the mini-spreader.

3.3 Tires on driving wheels

- When working with tires, secure the spreader so that it cannot move.
- Tire change should be performed on a stable base in which the wheel cannot become embedded. After every tire change, tighten the nuts after the first 10 work-hours, and then check their tightness every 50 work-hours.
- The air pressure is to be checked regularly. Use the recommended pressure 350 bar.
- Dismantling the wheels can be carried out only in the case when the spreader is not loaded.
- Avoid quick and variable maneuvers and high speed during turns.
- Tire valves are to be protected with caps to prevent penetration of impurities.

3.4 Adapter drive system

During maintenance of the adapter's drive, first make sure that the mini-spreader is secured against uncontrolled movement:

- chocks disabling free movement of the mini-spreader have been placed under the wheels,
- the mini-spreader is decoupled from the towing vehicle,
- the control lever is in the angled position (drive disengaged),
- if the mini-spreader has not been decoupled from the towing vehicle, always make sure that the keys have been removed from the ignition switch.

After checking the above points, it is not possible to start work on the adapter's drive.

3.5 Maintenance.

- Repair, maintenance and cleaning as well as removal of malfunctions can be performed only if the engine of the machine drawing the mini-spreader is switched off and the key has been removed from the ignition switch.
- During maintenance and repair jobs use appropriate tools and protective clothing.
- Maintenance should be performed standing on the floor outside of the spreader's outline.
- Use the spare parts according to the catalog of spare parts.
- Modifications can be made only with the permission of the manufacturer. The basic condition for safety are original spare parts and components. Using other parts may result in exclusion of liability of the manufacturer for resulting consequences.
- Maintenance operations of the spreader should be carried out on a stable surface and with securing the spreader against uncontrolled rolling off (through planting of chocks under the wheels);

3.6 The principles of movement on public roads.

	<p>NOTE!</p> <p>The machine is not designed for driving on public roads due to the absence of lighting. Driving on public roads is strictly prohibited. The spreader is intended for work on a farm or property under conditions of good visibility.</p>
---	---

- The presence and transport of people in the load crate of the spreader is prohibited.
- Before driving, make sure that the mini-spreader is correctly coupled to the drawing vehicle (in particular, check that the ball is properly locked in the hitch).
- It is forbidden to park on the slopes with a loaded and unsecured machine.
- Prior to each spreader's use, check its technical condition, especially in terms of safety. In particular, check the technical condition of the hitching system and driving system.
- The spreader is adapted for driving on slopes up to a maximum inclination of 8°. Moving the spreader on steeper slopes may cause the spreader to tip over as a result of loss of stability.
- It is prohibited to exceed the admissible spreader load. Exceeding the carrying capacity may lead to equipment damage, loss of stability while driving, scattering of the load and cause a hazard to third parties during driving.
- The load on the spreader must be distributed evenly and cannot make it difficult to drive the set or exceed the maximum tolerable pressing force on the hitch of the drawing vehicle.
- Take special caution when driving in reverse.
- It is prohibited to reverse while the spreader's drive is running.
- Re-loading of the mini-spreader increases the load on the rear axle of the drawing unit and results in loss or deterioration of this vehicle's maneuverability.

3.7 Description of residual risk.

Although the "CYNKOMET" Czarna Białostocka company takes responsibility for the design and construction in order to eliminate the danger, and has made every effort to eliminate the risk of an accident, some elements of risk during operation of the spreader are unavoidable. The

residual risk stems from the wrong behavior of the machine operator.

The greatest danger occurs when you do the following:

- Use the spreader for purposes other than those described in the manual.
- Being between the spreader and the tractor during work of the engine connecting the spreader to the tractor, or just being between machines during maneuvers, reversing, turning, or aggregation of the spreader to the tractor.
- Operation of the machine drawing the mini-spreader by unlicensed persons, minors or persons under the influence of alcohol or other drugs.
- When people/animals are present on the machine while it is running.
- Cleaning/maintenance of the machine when not following the instructions in the user's manual.
- Not keeping a safe distance when operating the machine (including reversing, driving, spreading materials for which the mini-spreader has been designed).
- Introduce structural changes without the consent of the Manufacturer.
- Clean, carry out maintenance and technical checks of the mini-spreader.
- Presence of people or animals in hazardous zones during the spreader's work (driving with engaged feed).
- Inserting arms, legs, or other items such as tools into rotating parts of the adapter, or the conveyor elements.

When presenting the residual risk, the spreader is treated as a machine, which until the start of production was designed and manufactured according to applicable standards.

3.8 Residual risk assessment.

When observing such recommendations as:

- Careful reading of the operating instructions and strict adherence to its provisions.
- Prohibition of placing hands and other parts of the body in inaccessible and forbidden places.









- prohibition of being on the machine during operation of the tractor, spreader
- Maintenance and repair of the machine according to instructions.
- Use of the machine by persons who have read the instruction manual.
- To work with the components and elements with sharp edges you must use suitable protective clothing (gloves, boots, etc.).
- securing the machine against the access of children and animals,
- use of the observations and recommendations contained in the operating instructions.
- Keep a safe distance from forbidden or dangerous places during the mini-spreader's work (spinning parts of the adapter).
- Prohibition on being on the machine during driving, working, loading or unloading.



	<p>NOTE!</p> <p>Residual risk is present in the case of failure to adhere to the tips and guidelines given in the instruction manual.</p>
--	--

3.9 Information and warning stickers.

The spreader is marked with information and warning labels listed in table 1. The user of the machine is obliged to take care of the readability of the subtitles, warning symbols and information placed on the mini-spreader throughout the entire period of its use. In the case of destruction, replace them with new ones. Labels with inscriptions and symbols are available from the manufacturer or the place where the machine was purchased. New units replaced during repairs must be re-marked with the appropriate safety signs. The use of warning stickers (pictograms) serves to remind the user and bystanders of the hazards that are present. When cleaning the spreader, do not use solvents that can damage the coating of labels and do not direct a strong stream of water.

Table 1. Information and warning stickers

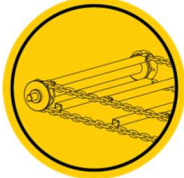
Item no.	The symbol (sign) of safety or the content of the inscription	Meaning of the symbol (sign)	The placement on the machine
1.		Note Before starting work, please read the User's Manual.	Front wall
2.		Note Turn off the engine and remove the key before starting maintenance or repair	Front wall
3.		Do not reach into the crushing area if parts may be in motion.	Side guards of drives
4.		Company logo	Front wall, rear adapter guard
5.		Product name	Right side wall, left side wall
6.		Logotype	The right-side wall, left side wall
7.		Speed limit	Rear adapter guard
8.		Load capacity	Right side wall, Left side wall
9.		Marking of drive	Front wall

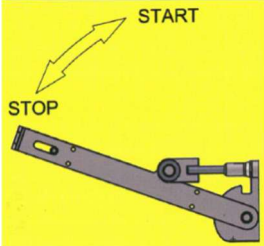
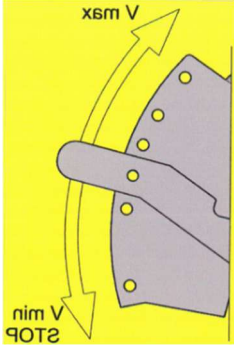
<p>10.</p>		<p>Marking of drive</p>	<p>Front wall</p>
<p>11.</p>		<p>Keep a safe distance from the machine</p>	<p>Side guards of drives</p>
<p>12.</p>		<p>Conveyor</p>	<p>Right side wall, Left side wall</p>
<p>13.</p>		<p>Drive engage lever</p>	<p>Left side wall</p>
<p>14.</p>		<p>Conveyor feed adjustment</p>	<p>Left adapter guard</p>

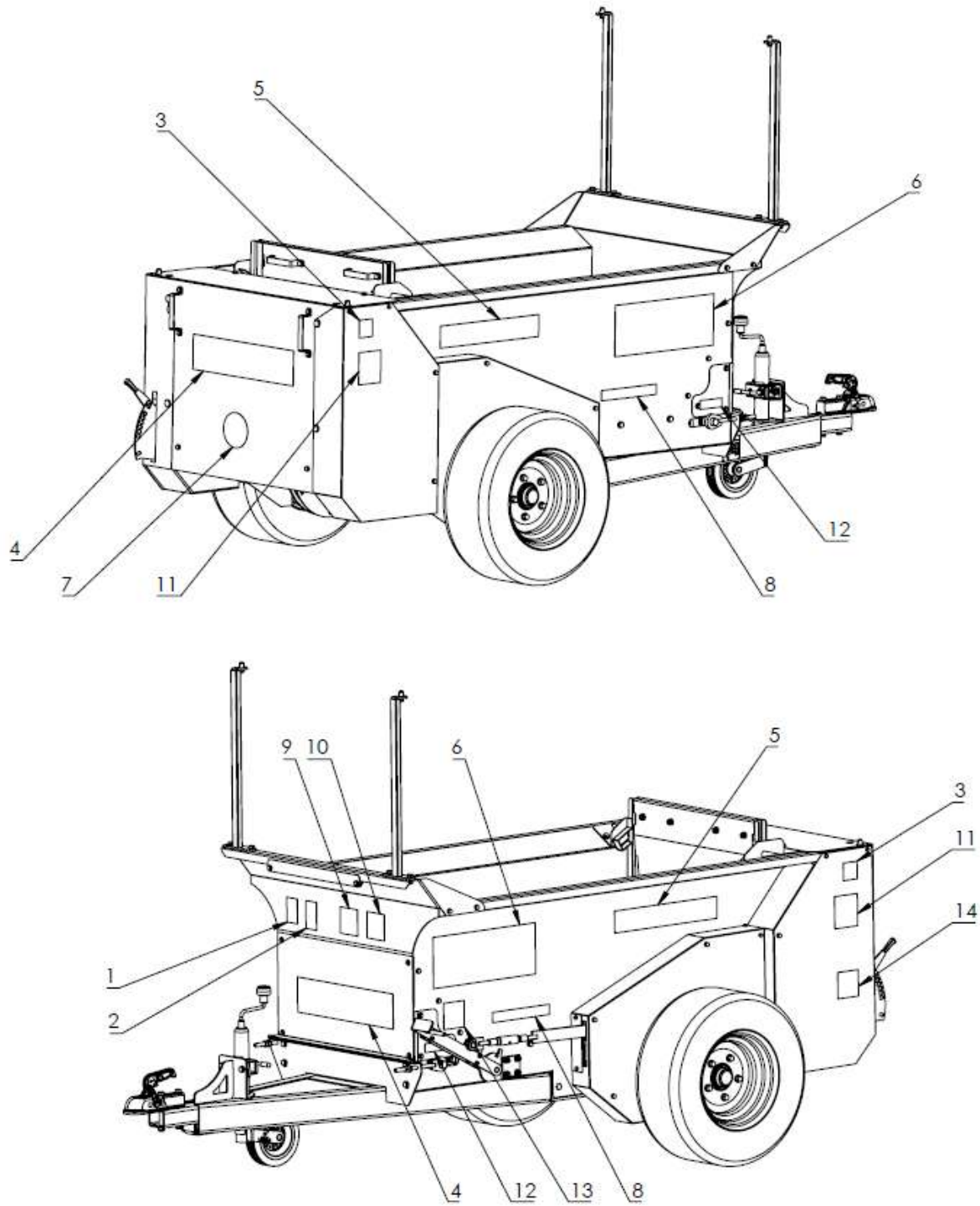

Figure 2. Distribution of stickers

3.10 Technical characteristics.

Table 2. Basic technical specifications of the trailer

Item No.	Content	Unit of measure	"DZIK"
1.	Total length	mm	3070
2.	Total width	mm	1380
3.	Total height	mm	910
4.	Track of wheels	mm	1090
5.	Dimensions of the loading crate: <ul style="list-style-type: none"> • Length • width • height 	mm	1560 700 510
6.	cargo capacity	m ³	0.6
7.	Loading surface	m ²	1.02
8.	Height of the loading surface	mm	345
9.	The ground clearance of the vehicle	mm	180
10.	Vehicle weight	kg	420
11.	Allowed payload of the vehicle	kg	800
14.	Tire size		23x8.5-12 Mitas 6 PR
14.3	The maximum tire pressure	bar/kPa	350
16.	Permissible design speed	km/h	15
18.	The level emitted of noise	dB	<70

4. Information regarding use

4.2 Description of construction and operation.

4.2.1 General description

The mini-spreader is a machine intended for spreading of manure of any type, peat, compost and cut grass. The spreader consists of cargo box (6), joined by screws to drawbar (3). The drawbar consists of two stringers terminated by a latch to which hitching head (1) and support with

maneuvering wheel (2) are fastened. Adapter (12), consisting of two horizontal drums to which blades are joined, is an integral part of the mini-spreader. We also include as standard equipment interior wall (8), which serves to stop the material being spread so that it does not spill out of the spreader and so that the adapter's drums are not clogged by the material being spread, before the material builds up. The spreader also has drives of the adapter and conveyor as well as rear adapter guard (13).

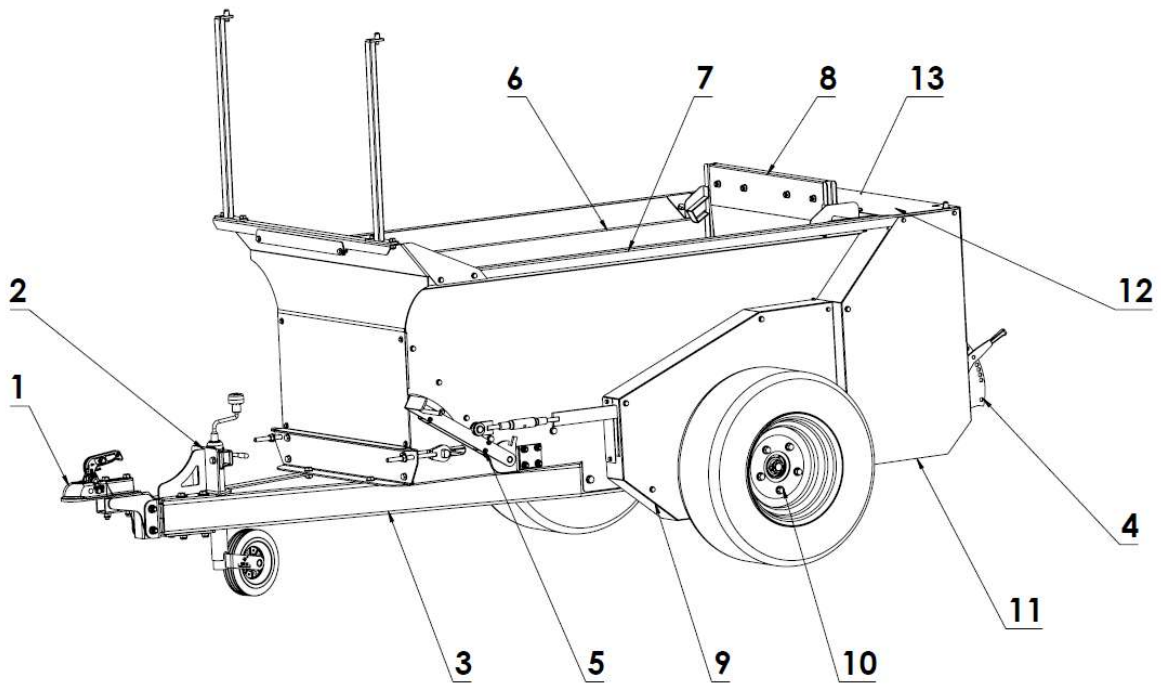

Figure 3. Structure of the "DZIK" mini-spreader

1 – hitching head; 2 – support with maneuvering wheel; 3 – drawbar; 4 – conveyor control; 5 – adapter control; 6 – cargo box; 7 – conveyor; 8 – interior wall; 9 – side drives with guards; 10 – axle with wheels; 11 – side adapter guards; 12 – adapter; 13 – rear adapter guard

4.2.2 Lower frame / drawbar

The lower frame consists of two stringers (5,6) and hitch (3), to which parts such as hitch (2) and hitching head (1) as well as support with maneuvering wheel (4) are fastened, and the lower frame (drawbar) is fastened to the cargo box at several points.

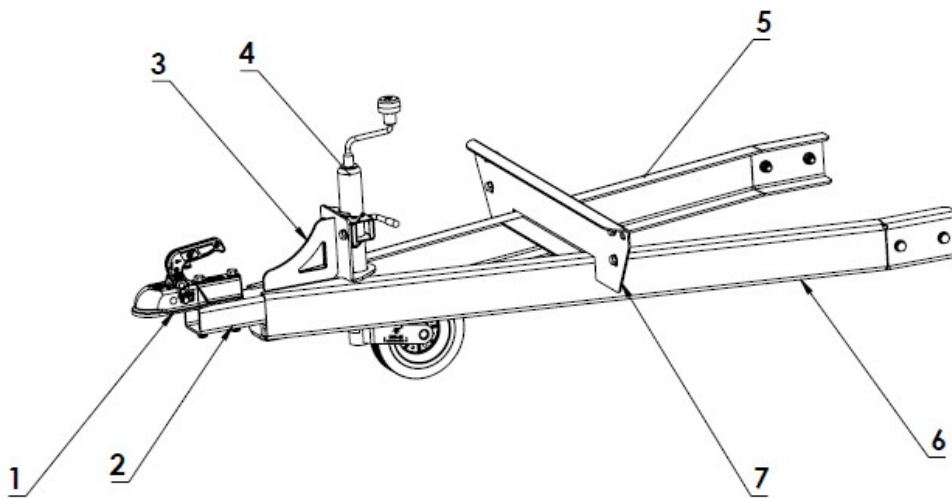

Figure 4. Lower frame / drawbar along with components
1 – hitching head; 2 – head hitch; 3 – support brackets; 4 – support with maneuvering wheel; 5 – right stringer; 6 – left stringer; 7 – reinforcing channel bar

4.2.3 The upper frame / loading crate

The cargo box consists of walls (1,2,3) fastened to one another by screws. The floor panel (4) along with angle braces (5) are fastened to the walls, improving the cargo box's rigidity. All components of the cargo box are made from hot-galvanized, 3 mm-thick sheets.

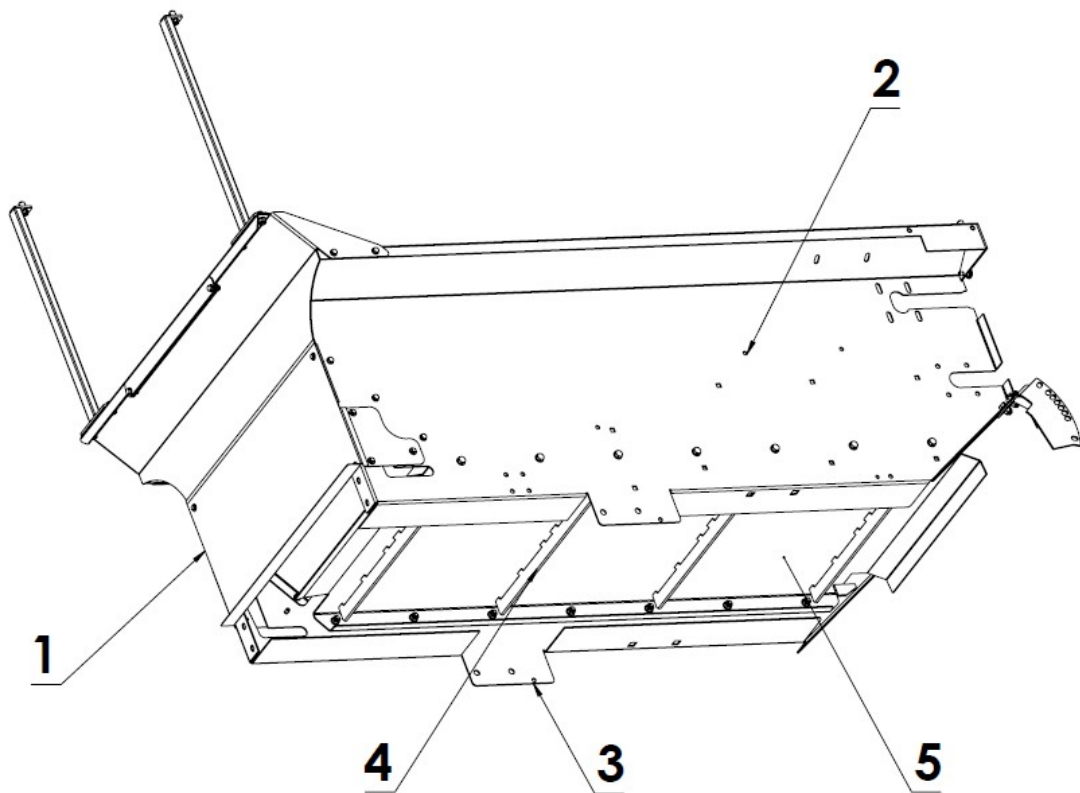

Figure 5. Cargo box along with components
1 – front wall; 2 – left wall; 3 – right wall; 4 – floor panel; 5 – cross-bar

4.2.4 Adapter

The adapter consists of the adapter's horizontal drums along with blades (1,2), which are fastened to the side walls of the mini-spreader (3,4).

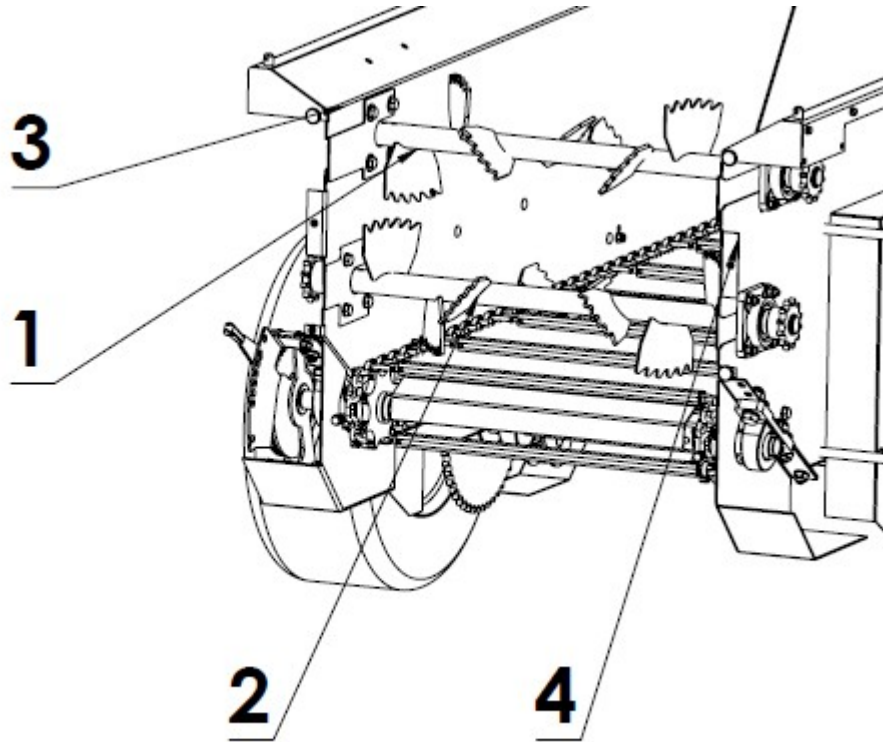

Figure 6. Adapter along with components

1 – top adapter drum; 2 – bottom adapter drum; 3 – left wall;

4 – right wall

4.2.5 Drives

The "Dzik" mini-spreader has two types of drives. One of them is the adapter's drive (fig. 8), consisting of a set of chain wheels, and the other is the conveyor's drive (fig. 7), where the executive component is a ratchet-wheel.

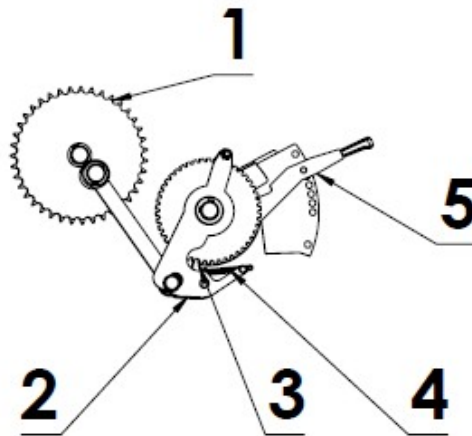

Figure 7. Conveyor's drive along with components
1 – chain wheel; 2 – ratchet mechanism; 3 – ratchet; 4 – spring; 5 – feed adjustment

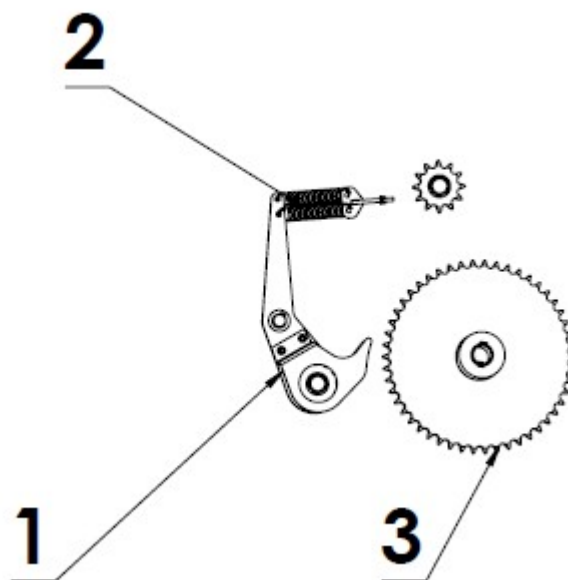

Figure 8. Adapter's drive along with components
1 – tensioner; 2 – tensioning springs; 3 – chain wheel

4.3 Rules of proper use of the spreader.

4.3.1 Preparation before running for the first time.

4.3.1.1 Control of the spreader after delivery

The manufacturer guarantees that the mini-spreader is fully operational and complete, and has been checked according to quality control procedures at the plant and is approved for use. However, this does not relieve the user from the obligation of checking the vehicle after delivery and before first use. The machine is provided to the user in a complete state.

Before starting work, the operator of the spreader must carry out an inspection of the technical condition of the spreader and prepare it for the first run. Please refer to the content of this manual supplied with the spreader and apply the recommendations contained in it, take a look at the design and understand the principle of operation of the machine.

 NOTE!	NOTE! Before connecting and before starting the spreader, read this manual and follow the instructions contained therein.
--	---

External visual inspection:

- Check the machine's completeness (presence of all guards, etc.).
- Check the condition of the anti-corrosion coatings.
- Perform a visual inspection of the individual components of the spreader for mechanical damage resulting inter alia due to improper transport of the machine (dents, piercing, bending or broken components).
- Check the condition of tires of the driving wheels and the air pressure in the tires.

4.3.1.2 Preparing the spreader for the first connection.

Preparation

- Check for proper tightening of nuts fixing the driving wheels.

- Make sure that the hitch on the drawbar of the mini-spreader is adapted to the ball hitch of the drawing vehicle.
- Check whether all guards are in place and their condition does not raise doubts.

Trial drive / start

If all the above steps have been performed and the technical condition of the spreader does not raise any objections, connect the machine to the drawing vehicle in compliance with the following sequence:

- Switch off the machine to which the mini-spreader is to be coupled (remove the key from the ignition switch).
- Couple the spreader to the ball hitch by pulling it manually to the drawing vehicle, and make sure that the drive control lever is in the angled position (drives disengaged).
- Couple the spreader, making sure that the coupling is working correctly (secure the coupling).
- Raise the adjustable support and set the wheel of the support facing up (so that during driving it does not catch on the ground).
- Remove the rear adapter guard and fasten it on the brackets on the front wall of the spreader, and secure it with safety pins.
- Raise the interior wall to the inclined position, the wall should be found within the channel bars of the fastening.
- Engage the drives of the adapter and chain conveyor with the mini-spreader's driving wheels by setting the lever from angled position (1) to vertical position (2), as shown in (figure 9).

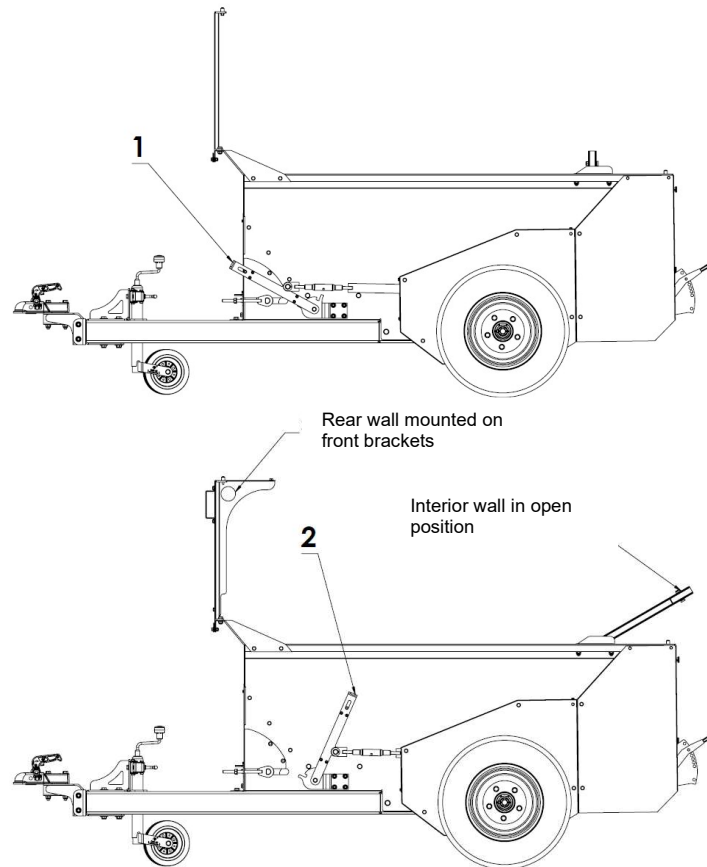

Figure 9. Control lever positions

- 1 – angled position (drives disengaged);
- 2 – vertical position (drives engaged)

- Start the drawing machine.
- Move the whole set by a few meters.

If during the test drive/start up, you experience disturbing symptoms such as:

- Noise and unnatural noises coming from the rubbing of moving parts on the construction of the spreader or other malfunctions, the problem should be diagnosed. If a fault cannot be removed or removing it will invalidate the warranty, please contact your dealer to resolve or repair the problem.



NOTE!

NOTE!

It is absolutely forbidden to leave the drawing machine with the engine running and the key inserted in the ignition.



NOTE!

NOTE!

Take special caution when two people are conducting an inspection. Do not attempt to make adjustments or insert hands into hazardous places while one of the operators is found on the drawing vehicle.



NOTE!

NOTE!

It is prohibited to drive the mini-spreader while its drives are engaged, when the interior wall is closed and the rear guard is not mounted on the front brackets.

After completion of the test drive / start-up, check the tightness of the nuts of the driving wheels, with the engine switched off (key removed from the ignition).

 <p>NOTE!</p>	<p>NOTE!</p> <p>Careless and improper use and operation of the spreader, and non-compliance with the recommendations contained in this manual poses a threat to the health.</p> <p>It is forbidden to use the spreader by persons not authorized, not qualified to drive the machines to which the spreader will be coupled, including under aged persons and persons under the influence of alcohol or other drugs.</p> <p>Failure to observe the rules of safe use poses a threat to the health and life of the operator and third parties.</p>
--	--

4.3.2 Preparation for the spreader's work.

In preparation for the spreader's work, the following should be checked:

- The wear of the tires and driving wheels.
- Air pressure in the tires.
- Tightening the nuts fixing the discs of the driving wheels to wheel hubs and the condition of other screw connections.
- Tightening of nuts fastening the hitching head to the hitch.
- Tightening of nuts fastening the hitch to the lower frame (drawbar).

In addition, after combining the machine with the tractor check:

- Correctness of hitch operation (locking of hitch).

4.3.3 Loading the spreader.

Loading of the spreader should take place after proper connection of the mini-spreader to the drawing machine, with the tractor engine off and key removed from the ignition switch. Loading should be performed while the spreader is standing on a flat surface, with an inclination of no more than 8 degrees. Loading should be

done manually due to the mini-spreader's low maximum load capacity. Loading is to be performed in such a way that the material loaded onto the cargo bed is evenly distributed. The goal of the uniform loading is to optimize the dispersion of the material during operation of the spreader and its stability.

	<p>NOTE!</p> <p>It is absolutely required from the user to verify whether the material loaded on the spreaders are not solids such as stones, pieces of wood, metal parts, wires, etc., and if so, to remove them immediately. Failure to do so may result in permanent damage to the structure of the machine and void the warranty, and what is worse impact of such elements on bystanders or animals.</p>
---	--

	<p>NOTE!</p> <p>Loading of the spreader with aggregated material should be done gradually depending on the material being spread and the substrate over which the spreader will be moving.</p>
---	---

4.3.4 Coupling and decoupling with the drawing machine.

The spreader can be coupled to a drawing vehicle that has a ball hitch adapter for hitching with a BC-1200 hitching head.

Coupling and decoupling should always be done manually, while drives are disengaged (angled lever position).

	<p>NOTE!</p> <p>Coupling of the spreader using a hitch other than the ball hitch is prohibited, as it poses a safety hazard to the operator and to</p>
---	---

	<p>bystanders who may be present in the danger zone.</p> <p>After completion of the machine coupling, check the security of the hitch.</p>
--	--

 <p>NOTE!</p>	<p>NOTE!</p> <p>When disconnecting the spreader from the tractor, keep particular caution.</p> <p>The engine of the vehicle drawing the mini-spreader must be turned off and its key removed from the ignition switch.</p>
--	---

4.3.5 Loading the cargo box.

 <p>NOTE!</p>	<p>NOTE!</p> <p>Loading of the cargo box may be performed only when the mini-spreader is coupled to a drawing vehicle and standing on level ground, with the parking brake of the drawing vehicle engaged.</p>
--	---

You should aim for even distribution of the load in the cargo box which has a significant impact on the uniformity of dispersion of the material found on the spreader and its stability during driving. Prior to starting loading, check whether the interior wall is closed and the conveyor and adapter drive control lever is found in the disengaged position (angled lever position).

Lightweight, bulk materials may be loaded even above the cargo box, however, up to 5 cm at the most, with particular attention to the stability of the spreader.

Due to the varied density of the materials, the use of the total capacity of the cargo box may result in exceeding the permissible load of the mini-spreader.

	<p>NOTE!</p> <p>It is advised to aim at an even distribution of the load in the loading crate.</p>
---	---

	<p>NOTE!</p> <p>It is prohibited to exceed the admissible spreader load, because this poses a safety risk and might cause damage to the machine.</p>
---	---

	<p>NOTE!</p> <p>Overloading the spreader, incompetent loading are the most common causes of accidents during transport. The load must be arranged so as not to threaten the stability of the spreader and not obstruct driving the set.</p>
---	--

	<p>NOTE!</p> <p>Observe strictly that there are no bystanders in the loading zone and during work of the spreader. Before commencing the loading of the spreader and during its work, ensure that there is proper visibility and make sure that there are no bystanders nearby.</p> <p>The distribution of the load cannot cause an overload of the driving system or the spreader's hitching system.</p>
---	--

4.3.6 Load transport

Drive with care and act reasonably. Below are the most important tips for driving a drawing vehicle with an attached mini-spreader.

- Before starting, make sure that in the vicinity of the spreader and the drawing vehicle there are no bystanders. Ensure sufficient visibility.
- Make sure that the spreader is properly connected to the vehicle, and the hitch is properly secured.

	<p>NOTE!</p> <p>Before driving, make sure that all of the spreader's components are in a generally good technical condition (no mechanical damage).</p>
---	--

- Do not exceed the maximum designed speed, equal to 15 km/h. Travel speed must be adapted to the prevailing conditions, spreader load, type of cargo and other weather conditions.
- Avoid ruts, depressions, ditches or driving on slopes of the road. Driving through such obstacles can cause sudden tilting of the spreader. This is particularly important because the center of gravity of the spreader adversely affects driving safety. Driving near the edge of ditches or canals is dangerous because of the risk of landslides under the wheels of the spreader or drawing vehicle.
- The driving speed must be reduced early enough before driving to the corners, when driving on uneven or sloping terrain.
- When driving avoid sharp corners, especially on slopes.
- Please note that the braking system increases significantly with increasing mass of the traffic load and increase in speed.
- Control the behavior of the spreader while driving on uneven terrain, and adjust the speed to terrain and traffic conditions.
- The spreader is adapted for driving on slopes of maximally up to 8°. Moving the spreader through the grounds of steeper slopes may cause the spreader

to tip over as a result of loss of stability. Prolonged moving on an incline poses a risk of loss of braking efficiency.

 NOTE!	NOTE! Be extremely careful when opening and closing the interior wall because of the risk of crushing fingers or hands.
--	---

Equipment and accessories

Table 3. Equipment of the mini-spreader

Equipment	Standard	Option
Instruction manual and spare parts catalogue	•	
Warranty Card	•	

4. Technical Support



When using the spreader, constant monitoring of the technical condition and the execution of maintenance procedures is required to keep the machine in good technical condition. Therefore, the user of the spreader is obliged to perform all maintenance and regulatory tasks specified by the Manufacturer.

In order to function properly and to avoid serious failure of the spreader, it must be kept in good technical condition, repaired on time and reasonably exploited (operation within the technical parameters of the spreader). After every use of the mini-spreader, clean the couplings of the driving axle. Failure to do so may lead to jamming of the clutch.

An important part of exploitation is daily technical maintenance of the spreader. Maintenance before starting work involves:

- Control of tightening the screw connections and securing them against unauthorized untightening (table 6).
- Check the correct operation of control mechanisms.
- Lubrication according to instructions.
- Checking the tire pressure.

All detected faults are to be removed as soon as they are detected. Prohibition on use of an unserviceable or incomplete machine.

 <p>NOTE!</p>	<p>NOTE!</p> <p>If you need to lift the driving wheel of the mini-spreader, observe the following rules:</p> <p>The spreader attached to the drawing vehicle is to be set in the direction for driving straight ahead on a flat, paved ground and then drawing vehicle should be braked.</p> <p>Under the wheels, which will not be lifted, plant securing chocks. Place a lift under the axle close to its joint with the cargo box and raise the axle so that the wheel does not touch the ground. Secure the spreader before falling placing a stand of appropriate height under the axle.</p>
 <p>NOTE!</p>	<p>NOTE!</p> <p>In the case of noting any irregularities in the operation or damage to systems or assemblies of the spreader, the machine must be taken out of use until repair and removal of defects. It is forbidden to carry out service and repair work under a burdened loading crate and with the drawing machine's engine running.</p> <p>All maintenance and repair tasks should be performed with the general principles of health and safety. In the case of injury, the wound should immediately be washed and disinfected. In the case of serious injuries, consult a physician.</p>
 <p>NOTE!</p>	<p>NOTE!</p> <p>Before starting work of the mini-spreader with engaged drives, the interior wall must be raised and the rear adapter guard removed and fastened on brackets on the front wall, and secured against falling out by inserting safety pins</p>

4.1 Adapter maintenance

Adapter maintenance involved checking whether there have been any losses on blades and the condition of their fastening to the drum. Lubrication of all 4 lubricating nipples on the adapter's drums must be performed. They

are found on bearing mounts.

	<p>NOTE!</p> <p>It is essential, before each use to check the status of the tightening of the adapter's blades. Failure to observe this activity can lead to severe damage to the machine or persons located in the proximal and distal distance from the working machine.</p>
<p>NOTE!</p>	

4.2 Conveyor feed adjustment.

Adjusting conveyor feed involves setting lever (1) from angled position to vertical position. This is done by pushing the lever upwards and removing the pin from its groove, then inserting it into another groove and releasing the lever so that the pin slides freely into the recess. This control causes coupling or decoupling of the cam-ratchet mechanism with the driving wheel's drive. In addition, conveyor feed can be changed using the lever found on the rear of the mini-spreader.

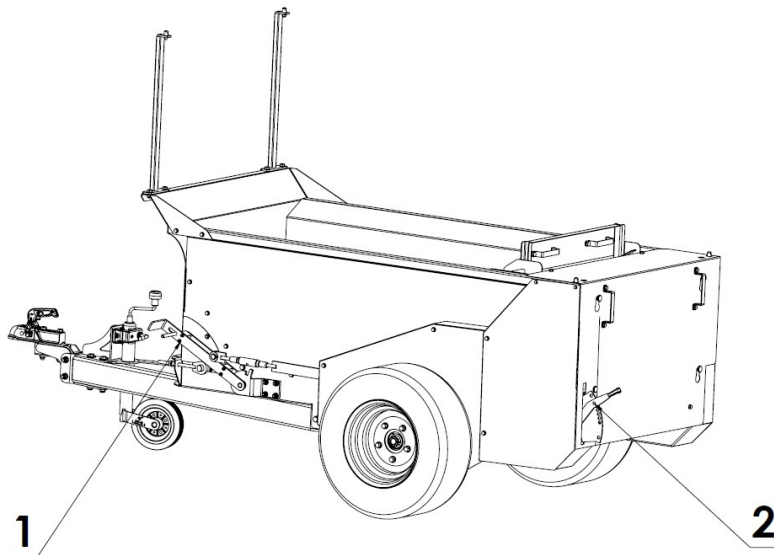

Figure 10. Conveyor feed control lever in off position

4.3 Adapter drive control.

Adapter drive control involves setting the lever from angled position to vertical position. This is done by pushing the lever upwards and removing the

pin from its groove, then inserting it into another groove and releasing the lever so that the pin slides freely into the recess. Such control causes coupling or decoupling of the chain wheel mechanism of the adapter's drive with the chain wheel mounted on the driving wheel.

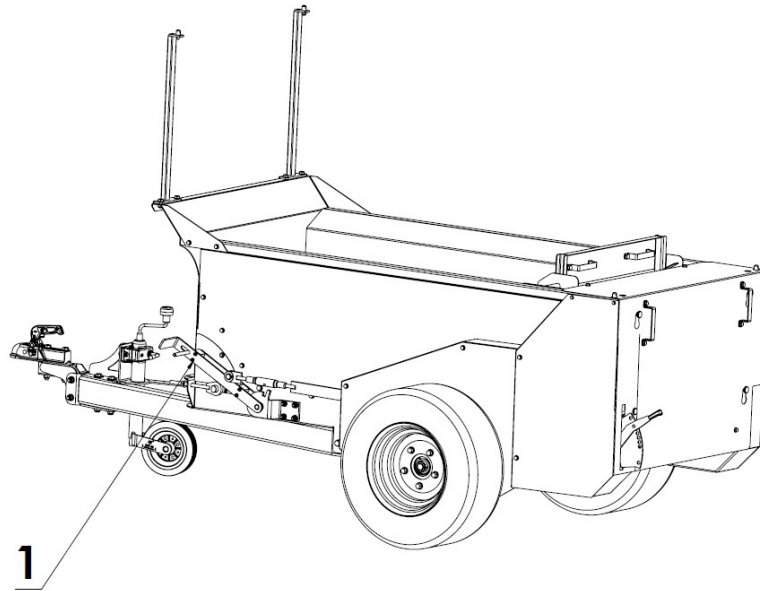

Figure 11. Adapter drive control lever in off position



NOTE!

NOTE!

It is essential before each use to check the state of tension of the chains and their technical condition (the thickness of the cells, whether the cells are not kneaded). Check whether any damage to or loss of the conveyor's strips has occurred.

4.4 Lubrication.

Lubrication of the "DZIK" mini-spreader should be carried out at the points specified in figure 20 and listed in table 4.

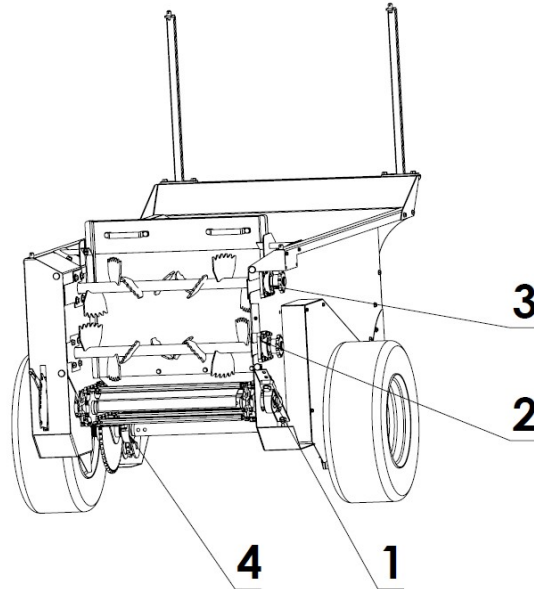

Figure 12. Lubrication diagram (spreader without rear and right guards)

Table 4. Frequency and method of lubrication of the mini-spreader's mechanisms

No. on Fig. 14	Place of lubrication	Number of lubrication points	Lubricant type	The frequency and method of lubrication
1	Spreader's rear shaft	2	Solid grease	Every 3-4 months.
2	Adapter's bottom drum	2	Solid grease	Every 3-4 months.
3	Adapter's top drum	2	Solid grease	Every 3-4 months.
4	Driving axle	2	Solid grease	Every 3-4 months.

Before commencing the lubrication of the grease fitting, the greased surfaces and places nearby lubrication points must be thoroughly cleaned of mud and dust. The grease should be injected in the grease fitting until release of fresh grease in the gaps between the mating parts. Drive chains must also be lubricated.

4.5 Preparing the spreader for work.

The rear adapter guard shown in (fig. 13) is an integral part of the spreader and plays a very important role.

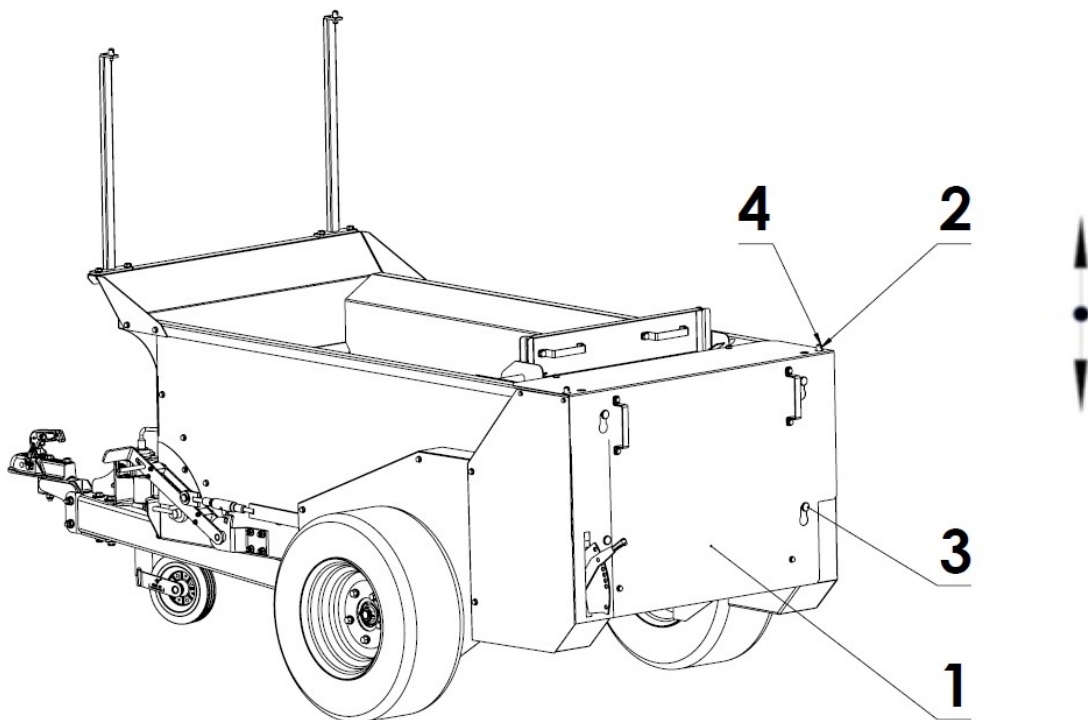

Figure 13. View of rear guard in fastened position on the adapter

1 – rear guard; 2 – safety pin; 3 – locking pin I; 4 – locking pin II

Start guard removal by removing the safety pin (2) from locking pin (4), then hold the grips fastened to the guard with both hands and raise it up until the guard comes off of pins (2) and (3).

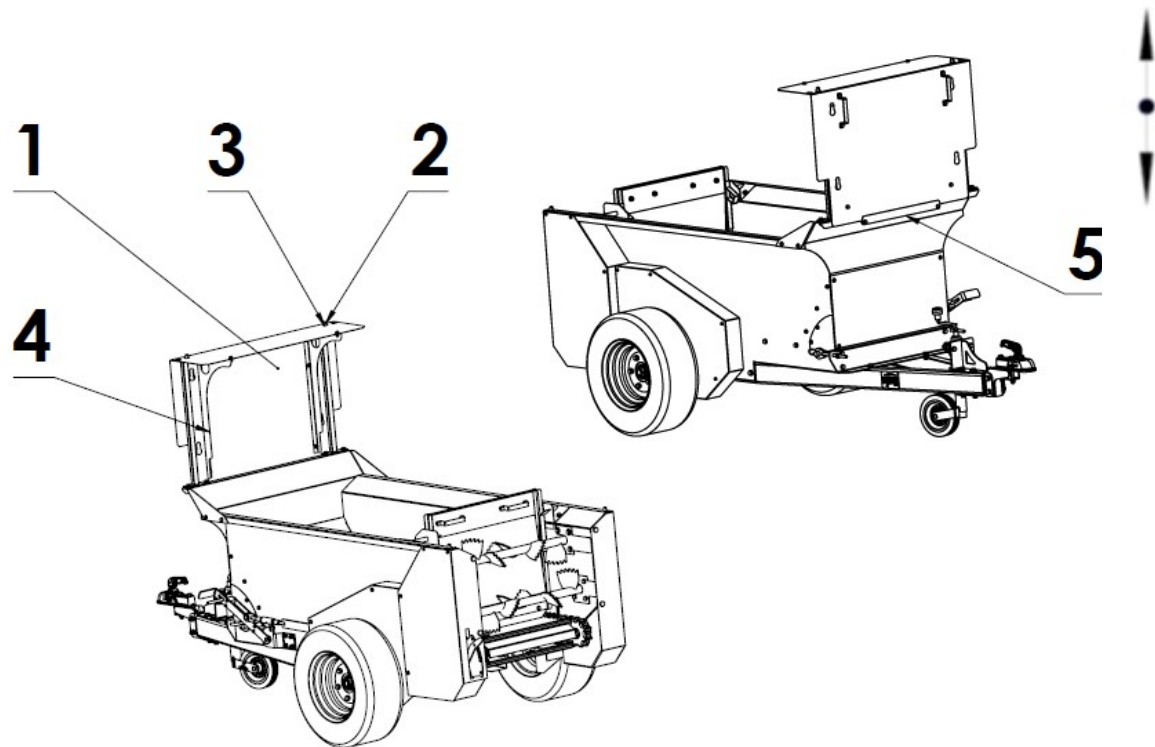

Figure 14. View of rear guard in fastened position on brackets 1 – rear guard; 2 – safety pin; 3 – locking pin II; 4 – guard bracket; 5 – front limiting sheet.

After dismantled the guard from the rear part of the adapter, fasten it on the brackets on the front wall. Start this process by fastening the guard's brackets to the spreader's front wall using the screws attached. Next, move the guard towards the wall so that the end of guard (1) can slide freely between the mini-spreader's front wall and limiting sheet (6). Pin (4) should enter the hole found in guard (1). Such relocation of the guard from the adapter to the front wall's brackets should be secured by inserting safety pin (2) through locking pin (4).

The mini-spreader is equipped with an interior wall that prevents the cargo from spilling while driving. The wall is raised and lowered manually. During loading, the wall should be in closed position, next, prior to spreading

of the material, it should be raised and inserted into channel bars in inclined position (fig. 15).

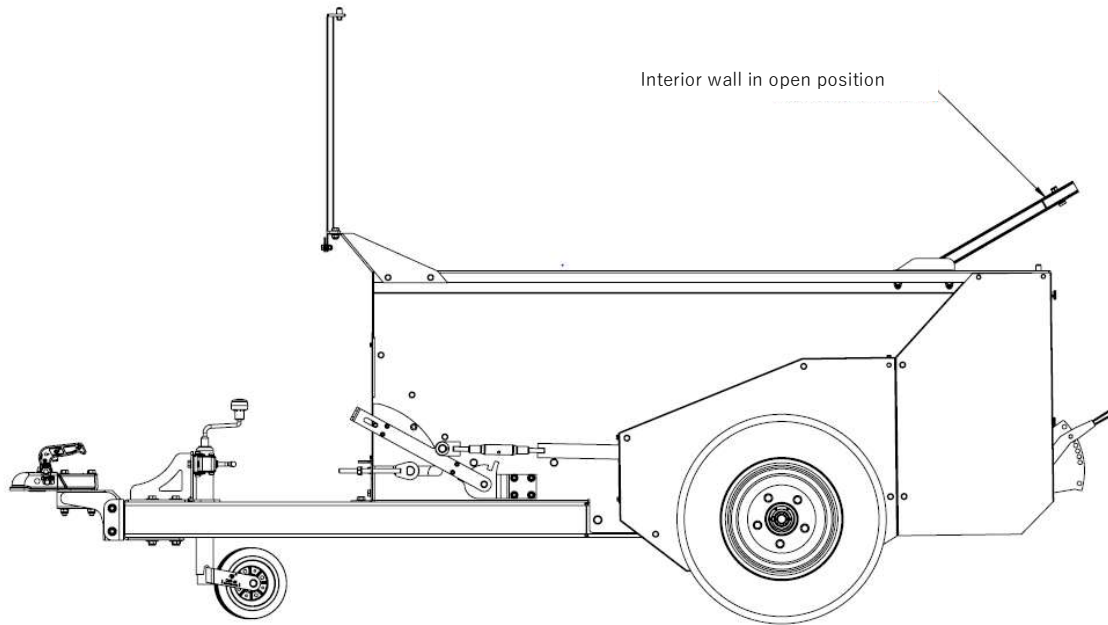

Figure 15. interior wall

4.6 Storage and maintenance.

After ending operation, the spreader must be carefully cleaned and washed with a stream of water, and then left it in a dry and ventilated area. In the event of failure of these actions on the zinc coating, dark and light gray areas (spots) may occur, which do not constitute grounds for complaint if the zinc coating still has the required minimum thickness (PN-EN ISO 1461: 2000). In the case of damage of the external paint coating, the damaged areas must be cleaned of rust and dust, degreased, and painted retaining the same color and uniform thickness of the protective coating. Until painting, the damaged areas should be covered with a thin layer of grease or anticorrosion preparation.

During a long break in the use of the spreader, it is desirable to place it indoors or in a covered, ventilated place. It is also advisable that the metal parts not coated with paint are secured with an anti-corrosion preparation of temporary protection or a layer of grease. During a long break in the use of the spreader, it cannot be loaded. After every use of the mini-spreader, clean the couplings of the driving axle. Failure to do so may lead to jamming of the clutch.

4.7 Troubleshooting.

Table 5. Faults and remedies

Failure	Reason	Way of removal
Problems with moving	Adapter drive blocked	Check whether the chain has not jammed on gears
	Conveyor drive blocked	Check whether the ratchet has not jammed
	Conveyor blocked	Check whether something is blocking the chain wheels
Noise in the hub of the driving axle	Excessive clearance on the bearings	Check clearance and adjust if necessary
	defective bearings	replace bearings
	damaged items	Replace
Uneven feed	Jamming of ratchet on ratchet-wheel	Check the condition of tensioning springs in the cam-ratchet mechanism
Uneven spreading of the material on the box	Unevenly loaded material	Distribute the material over the cargo box evenly
	Adapter's blades damaged	Check whether the blades on the adapter's drums are damaged

Tightening torques for screws.

For corrective maintenance work, use the proper tightening torques for the screw connections. The recommended tightening torques of the most commonly used screw connections are shown in the table below. The provided values refer to non-lubricated steel screws.

Table 6. Tightening torques for screws

Metric thread	Screw class		
	5.8	8.8	10.9
	Nm		
M6	5	7	11
M8	12	18	26
M10	23	35	52
M12	40	60	89
M14	64	98	144
M16	95	145	213
M18	133	209	297
M20	186	292	416
M22	247	389	553
M24	320	502	715
M27	464	729	1039
M30	634	997	1420

5. Transport

The spreader is prepared for sale in a completely assembled state and does not require packing unless the parties have declared delivery in a different form. Only the machine's instruction manual is packed.

Delivery of the spreader to the user takes place by transport on other machines homologated for driving on public roads and adapted for the transport of such machines.

Loading and unloading of the spreader from the vehicle must be carried out using an unloading ramp by means of a drawing vehicle (following the guidelines in the instruction manual concerning first start-up), crane or forklift. Manual towing of the mini-spreader from the vehicle onto a ramp is also permitted. During operation, observe the general safety rules with handling operations. Persons operating the reloading equipment must have the required permissions to use these devices.

When loading / unloading using an all-terrain vehicle/tractor, the spreader must be properly connected with the drawing machine according to the requirements contained in this manual.

When loading / unloading using a crane, the spreader is to be lifted with the help of approved fasteners designed to carry the load with sufficient capacity. The belts must be in good condition, they cannot show any signs of damage.

The belts should be placed under the lower frame of the spreader in such places that when lifting the machine the belts do not have the possibility of moving, and the spreader when moving is not tilting. If there is a possibility of damage or frayed belts against components of the machine, put washers in sensitive areas.

In order to avoid compression of the walls to the inside the spreader, when loading with the use of a crane, use a special traverse, where the places of hooking the belts will be spaced wider than the total width of the machine.

The spreader should be attached firmly to the platform of the transport mean with belts, chains, lashing or other fastening means equipped with a tightening mechanism. Frayed belts, cracked mounting brackets, opened or corroded hooks or other damage may disqualify the given mean for use.

Under the wheels of the spreader chocks, it is advisable to put wooden beams or other elements without sharp edges, preventing the machine from rolling. The spreader wheels chocks must be attached to the loading platform of the car so as to prevent their shifting.

**NOTE!**

The driver of the car, while transporting the machine, should take extra caution.

6. Spreader cassation

Should the user make a decision on cassation of the machine, he must pass the entire spreader to the scrap depot designated by the Governor or a Starost.

The dismantled parts remaining after repair of the spreader must be submitted to the collection point of recyclable materials.

7. Guarantee

"CYNKOMET" Sp. z o.o. in Czarna Białostocka ensures the smooth operation of the machine according to the technical-operational terms described in the operating manual. The condition of accepting a complaint is to follow all the recommendations contained in the operating and use manuals.