

TRAILER T-117/2

TECHNICAL SPECIFICATIONS | EQUIPMENT



✓ **HOMOLOGATION
EUROPEAN**



Year of model 2022

CynkoMet[®]
Czarna Białostocka

TECHNICAL SPECIFICATIONS	
Type / Variant / Version according to EU homologation	T-3 510,111
Administrative loading capacity	~5420 kg*
Technical loading capacity	~5420 kg*
Gross vehicle weight rating according to PL regulations	6,800 kg
Gross vehicle weight rating according to Directive 2015/208 (only load on axles)	5,800 kg
Kerb weight (without wall extensions)	~ 1,380 kg
Number of axles	1
Length	4,710 mm
Width	1,990 mm
Height without extensions	1,660 mm
Height with extensions	2,260 mm
Length of cargo box interior	3,345 mm
Width of cargo box interior front/rear	1,830 mm
Height of box walls cccc	600 mm
Height of platform from base	1,060 mm
Floor/wall sheet thickness	3 / 2.5 mm
Loading surface	6.1 m2
Loading capacity - without extensions / with extensions	3.7 m3 (7.3 m3)
Track of wheels	1,500 mm
Suspension	rigid
Max. vertical drawbar eye load	1,000 kg
Drawbar coupling height – min.	500 mm
Drawbar coupling height – max.	830 mm
Max. tolerable vertical load on axle	5,800 kg
Tire size	11.5/80-15.3
Design speed	30 km/h
Minimum demand for tractor power	36.8 kW / 50 HP
Tipping angle of the cargo box (backward / sideways)	45 / 50
Tipping system	three-way

* - unladen weight and loading capacity may differ depending on the trailer's equipment

STANDARD MACHINE EQUIPMENT

Wall height 600 mm with thickness 2.5 mm, hot-galvanized

Central bolt-locking of walls (bottom sideboards)

Exterior ladder and steps inside cargo box - hot-galvanized - with anti-skid steps facilitating access to cargo box

Maintenance support of cargo box, hot-galvanized

Rigid drawbar for coupling with the top or bottom hitch of the tractor, with replaceable eye, drawbar homologated according to Regulation 55UN ECE

Bolted hitch tension member dia. 40

Hot-galvanized frame of cargo box

Main stringers of cargo box frame made of 160x60x4 closed profiles

Galvanized cargo box floor made of single riveted and bolted sheet, thickness 3mm

Hot-dip galvanized bottom frame (protection of the structure on the exterior and interior of profiles), stringers of the frame made of metallurgical 160 and 140 channel sections, additionally closed by 5 mm sheet

Parking handbrake with crank

Grain chute, hot-galvanized, with blockade in the rear wall

Straight drawbar support with collapsible steel wheel, partially hot-galvanized

Homologated, hot-galvanized bumper

Tipping installation protected against excessive box inclination by cut-off valve

Lighting installation connector cable with 7PIN 12V plug

12V lighting, homologated, rear bulb lamps, LED perimeter lighting

Hydraulic tipping installation of cargo box made of galvanized steel tubes and flexible hoses

Hydraulic connectors to tractor, type ISO 7241-1 DN 12.5

Homologated, pneumatic double-circuit brake system with manual braking force adjustment

New 11.5/80-15.3 wheels

Axles from renowned ADR company, full beam with 70mm square cross-section, 300x60 brake

Two wheel chocks placed in galvanized pockets

Telescopic actuator with articulated suspensions, four-level with 1,300 mm pitch. Useful force at fourth level with diameter 105mm, at nominal pressure 16MPa = 138kN (~14T)

All of our agricultural machines are designed and tested by our design team using the latest available tools. Manufacturing is performed with the greatest diligence and in adherence to rigorous quality standards.

OPTIONAL MACHINE EQUIPMENT

Spare wheel hanger, hot-galvanized

Hot-galvanized tarpaulin frame made of 40x40x3 closed profiles

Hot-galvanized 600 mm wall extensions, thickness 2.5 mm

Chute for precise tipping, hot-galvanized

Hot-galvanized mesh wall extensions, height 1 000 mm

Full LED lighting

Homologated, hydraulic double-circuit brake system with manual braking force adjustment

Overrun braking system

11.5/80-15.3 spare wheel

400/60-15.5 wheels

400/60-15.5 spare wheel

Laced tarpaulin

Hydraulic quick-coupler with pressure neutralizer in hose

Warning triangle (sign distinguishing slow-moving vehicle)

DUPLEX - painted set of walls

DUPLEX - painted set of extensions

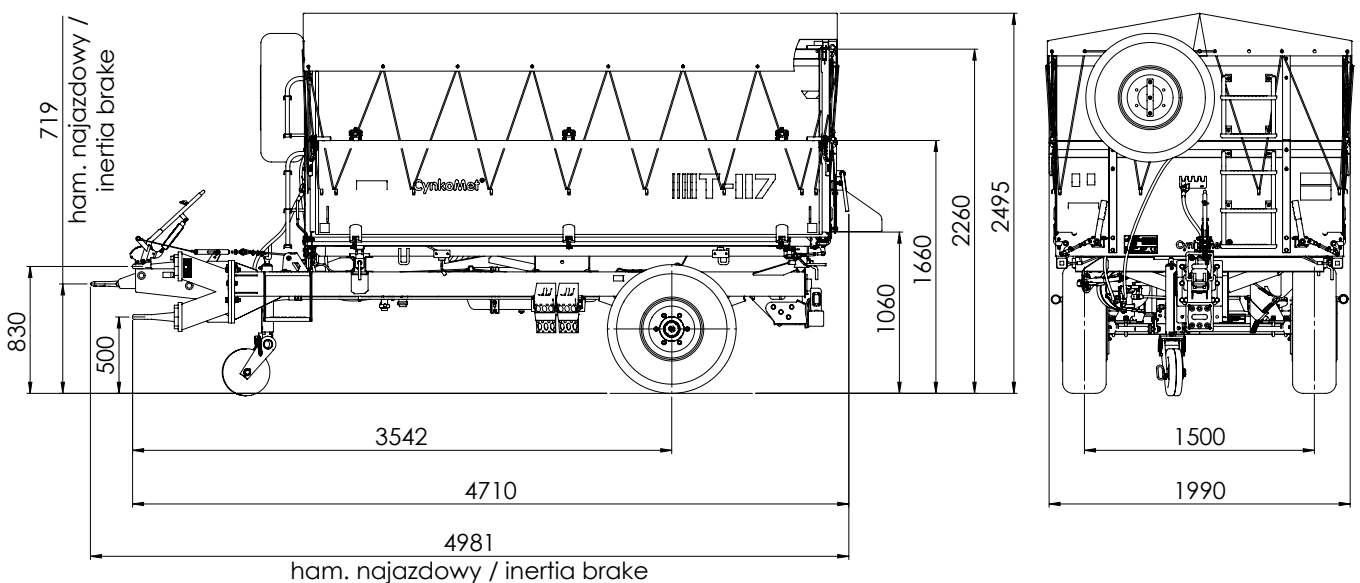

The data and photographs given in the catalog are for illustrative purposes only. This document and the information it contains, including prices, do not constitute a commercial offer within the meaning of art. 66 of the Civil Code. This information may be subject to change as products are continuously improved. We reserve the right to change a product's characteristics at any time.

Products' specifications may change without notice. Realization of an order begins when a person from our sales department confirms the data contained in the order form.



HOT-GALVANIZED CONSTRUCTION