

TRAILER T-104-4

TECHNICAL SPECIFICATIONS | EQUIPMENT



 **HOMOLOGATION
EUROPEAN**



Year of model 2022

version.1.2022

CynkoMet[®]
Czarna Białostocka

TECHNICAL SPECIFICATIONS

Type/version/variant	T-1/621/41
Technically (design) permissible total weight rating	11,000 kg
Gross vehicle weight rating	~11,000kg
Load capacity	~8,000 kg*
Kerb weight (without wall extensions)	~2,900 kg*
Length	6,566 mm
Width	2,440 mm
Height without extension	~1,775 mm
Height with extensions	~2,275 mm
Length of cargo box interior	4,435 mm
Width of cargo box interior	2,230 / 2,270 mm
Box wall height	500 (1000) mm
Loading surface	10m ²
Loading volume (with extensions)	5 (10) m ³
Height of floor above ground	~1,243 mm
Tire size	500/50 17
Floor/wall sheet thickness	4/2.5 mm
Track of wheels	1,700 mm
Wheelbase	3,000 mm
Drawbar coupling height – min.	600 mm
Drawbar coupling height – max.	900 mm
Coupling height of rear hitch (optional)	770 mm
Transport/working speed	40 km/h
Suspension	parabolic springs
Class of cooperating tractor	70 HP
Tipping angle of the cargo box (backward / sideways)	45/50
Tipping system	three-way

* - unladen weight and loading capacity may differ depending on the trailer's equipment

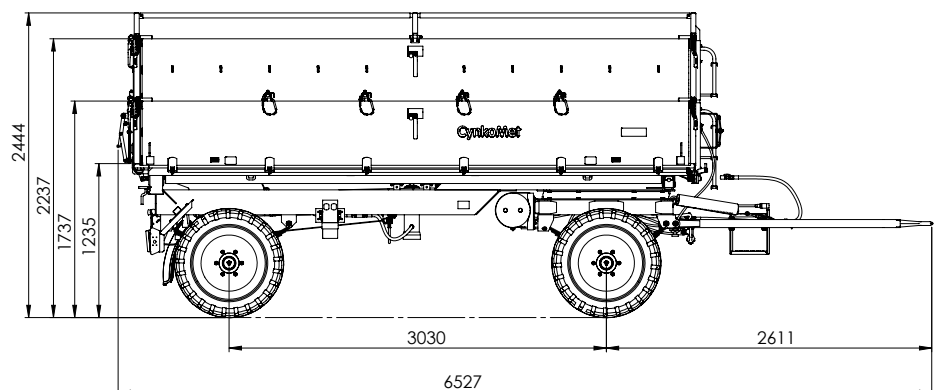
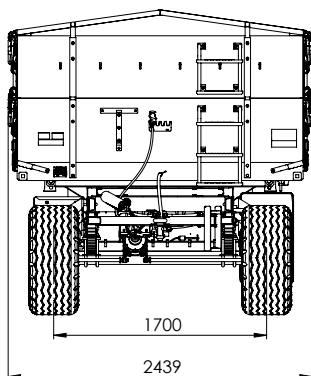

STANDARD MACHINE EQUIPMENT

Wall height 500 mm with thickness 2.5 mm, hot-galvanized

New 500/50 17 wheels

Axles from the renowned ADR company, homologated (EU 2015/68), bar cross-section - square 80, brake size 350x90 359E, 6 M18x1.5 pins

Central bolt-locking of walls (bottom sideboards)

Exterior ladder and steps inside cargo box - hot-galvanized - with anti-skid steps facilitating access to cargo box

Two wheel chocks placed in galvanized pockets

Telescopic actuator with articulated suspensions, four-level with 1,700 mm pitch. Useful force at fourth level with diameter 120mm, at nominal pressure 16MPa = 180kN (~18.3T)

The tipping installation is protected against excessive box inclination by a cut-off valve and by a safety valve in the event of damage to the feed hose

Maintenance support of cargo box, hot-galvanized

12V lighting, homologated, rear bulb lamps, LED perimeter lighting, rear socket for connection to second trailer

Lighting installation connector cable with 7PIN 12V plug

Side wall links

Homologated, double-circuit, pneumatic brake system with automatic braking force adjustment from HALDEX, with output for second trailer.

Parking handbrake with crank

Hot-galvanized frame of cargo box

Main stringers of cargo box frame made of metallurgical 160 channel sections

Cargo box floor made of single sheet, thickness 4 mm

Hot-dip galvanized bottom frame (protection of the structure on the exterior and interior of profiles), stringers of the frame made of 200x80x6 and 160x80x6 closed sections

Grain chute, hot-galvanized, with blockade in the rear wall

Hydraulic tipping installation of cargo box made of galvanized steel tubes and flexible hoses

Hydraulic connectors to tractor, type ISO 7241-1 DN 12.5

Triangular drawbar with adjustable support spring, with 40 mm eye, homologated according to Regulation 55UN ECE

Rear hydraulic and brake output to the second trailer

Hot-galvanized rear bumper, homologated according to Regulations 2015/504 and 167/2013

OPTIONAL MACHINE EQUIPMENT
Structural elements
Spare wheel hanger, hot-galvanized*
Hot-galvanized tarpaulin frame made of 40x40x3 closed profiles
Hot-galvanized 500 mm wall extensions, thickness 2.5 mm
Chute for precise tipping, hot-galvanized
Hot-galvanized work platform*
Side underrun guards
“Y”-type drawbar with exchangeable tip, homologated according to Regulation 55UN ECE and 167/2013*2015/208ND
Installations
Homologated, hydraulic double-circuit brake system with automatic braking force adjustment
Full LED lighting
Driving system
500/50 17 spare wheel*
Other equipment
Drawbar eye 50mm
Laced tarpaulin
Roll-up tarpaulin
Warning triangle (sign distinguishing slow-moving vehicle)
Hydraulic quick-coupler with pressure neutralizer in hose
Manual hitch for second trailer
Automatic hitch for second trailer
DUPLEX - painted set of walls
DUPLEX - painted set of extensions

* It is not possible to simultaneously mount the wheel hanger and work platform on the front wallboard

The data and photographs given in the catalog are for illustrative purposes only. This document and the information it contains, including prices, do not constitute a commercial offer within the meaning of art. 66 of the Civil Code. This information may be subject to change as products are continuously improved. The manufacturer reserves the right to change a product's characteristics at any time. Products' specifications may change without notice.



**HOT-
GALVANIZED CONSTRUCTION**