

TRAILER T-617/4

TECHNICAL SPECIFICATIONS | EQUIPMENT



 **HOMOLOGATION
EUROPEAN**



Year of model 2022

version.1.2022

CynkoMet[®]
Czarna Białostocka

TECHNICAL SPECIFICATIONS	
Technically (design) permissible total weight rating	21,000 kg
Gross vehicle weight rating	21,000 kg
Load capacity	15,500 kg
Unladen mass	5,500 kg
Length	7,500 mm
Width	2,550 mm
Height without extension	2,300 mm
Height with extension	2,800 mm
Length of cargo box interior	5,700 mm
Width of cargo box interior	2,195 mm
Box wall height	1,500 mm
Loading surface	12.5m ²
Cargo capacity	18.8 m ³
Height of floor above ground	1,250 mm
Tire size	385/65 R22.5
Floor/wall sheet thickness	4/5 mm
Track of wheels	1,900 mm
Drawbar coupling height - bottom position	360 mm
Drawbar coupling height - top position	560 mm
Max. tolerable vertical load on drawbar	3,000 kg
Coupling height of rear hitch (optional)	740 mm
Transport/working speed	40 km/h
Suspension	parabolic springs in tandem configuration
Class of cooperating tractor	110 HP
Tipping angle of the cargo box (backward)	50*
Tipping system	one-sided

* - unladen weight and loading capacity may differ depending on the trailer's equipment

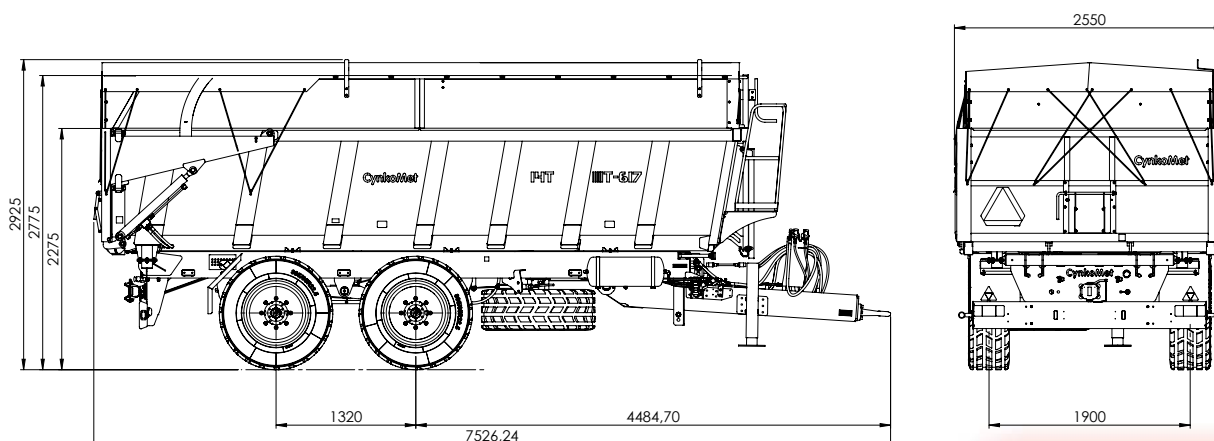

STANDARD MACHINE EQUIPMENT

Wall height 1,500 mm

New 385/65- 22.5 wheels

Axles from renowned ADR company, homologated (ECE R13)

Hot-galvanized, shock-absorbing drawbar, homologated according to EU Directive 2015/208

Hydraulic drawbar support with built-in hydraulic lock

Exterior ladder and steps inside cargo box - hot-galvanized - with anti-skid steps facilitating access to cargo box

Inspection window in front wall and in extension

Two wheel chocks placed in galvanized pockets

Telescopic actuator, five-level, pitch 2,400 mm. Useful force at fifth level with diameter 140 mm, at nominal pressure 20MPa = 307.9kN (31.4T)

Cross-bar linking extensions

Maintenance support of cargo box, hot-galvanized

12V lighting, homologated, for bulbs, with a rear socket for a second trailer, LED perimeter lighting

Lighting installation connector cable with 7PIN 12V plug

Pneumatic, double-circuit brake installation with output for second trailer

Parking handbrake with crank

Grain chute, hot-galvanized, with blockade in the rear wall

Cargo box frame painted in two steps (prime coat/topcoat) with high-grade PPG paints

Shell cargo box made of 4mm sheets (walls) and 5mm sheets (floor). Main stringers of cargo box made of 150x150x8 closed profiles

Hot-dip galvanized bottom frame (protection of the structure on the exterior and interior of profiles), stringers of the frame made of 250x150x8 closed sections

Hydraulic tipping installation of cargo box made of galvanized steel tubes and flexible hoses

Hydraulic connectors to tractor, type ISO 7241-1 DN 12.5

Rear hydraulic and brake output to the second trailer

Rear wall opened hydraulically

Hydraulic locks on actuators protecting against uncontrolled opening of rear wall

All of our agricultural machines are designed and tested by our design team using the latest available tools. Manufacturing is performed with the greatest diligence and in adherence to rigorous quality standards.

OPTIONAL MACHINE EQUIPMENT
Structural elements
Spare wheel winch with hot-galvanized wheel hanger
Hot-galvanized tarpaulin frame made of 40x40x3 closed profiles *
Chute for precise tipping, hot-galvanized
Hot-galvanized work platform
Ball hitch tension member dia. 80
Installations
Full LED lighting
Driving system
Surcharge for 550/45 R22.5 wheels
385/65 R22.5 spare wheel
550/45 R22.5 spare wheel
Self-steering axle
Other equipment
Roll-up tarpaulin *
Manual hitch for second trailer
Warning triangle (sign distinguishing slow-moving vehicle)
Hydraulic quick-coupler with pressure neutralizer in hose

* AVAILABLE ONLY WITH EXTENSIONS



The data and photographs given in the catalog are for illustrative purposes only. This document and the information it contains, including prices, do not constitute a commercial offer within the meaning of art. 66 of the Civil Code. This information may be subject to change as products are continuously improved. The manufacturer reserves the right to change a product's characteristics at any time. Products' specifications may change without notice.



**HOT-
GALVANIZED CONSTRUCTION**