

TRAILER T-617/5

TECHNICAL SPECIFICATIONS | EQUIPMENT



 **HOMOLOGATION
EUROPEAN**



Year of model 2022

CynkoMet[®]
Czarna Białostocka

TECHNICAL SPECIFICATIONS	
Type/version/variant	T-4/720/61
Technically (design) permissible total weight rating	21,000 kg
Gross vehicle weight rating	21,000 kg
including on axles max.	18,000 kg
including on drawbar max.	3,000 kg
Loading capacity (with/without set of extensions)	~15,500 / ~15,800 kg*
Unladen weight (with/without set of extensions)	~5,500 / ~5,200 kg*
Length	7,250 mm
Width	2,550 mm
Height without extension / with 1 extension / with 2 extensions	~ 2,096 / 2,596 / 3,100 mm
Length of cargo box interior	5,130 mm
Width of cargo box interior	2,420 mm
Box wall height	500 mm
Loading surface	12.4 m ²
Loading volume standard / with 1 extension / with 2 extensions	6.2 / 12.4 / 18.5 m ³
Drawbar coupling height - bottom position	380 mm
Drawbar coupling height - central/ top position	610/860 mm
Max. tolerable vertical load on drawbar	3,000 kg
Coupling height of rear hitch (optional)	870 mm
Height of floor above ground	~1,565 mm
Tire size	385/65 R22.5
Floor/wall sheet thickness	5/2.5 mm
Track of wheels	1,900 mm
Transport/working speed	40 km/h
Suspension	parabolic springs in tandem configuration
Class of cooperating tractor	110 HP
Tipping angle of the cargo box (backward / sideways)	45/50
Tipping system	three-way

* - unladen weight and loading capacity may differ depending on the trailer's equipment

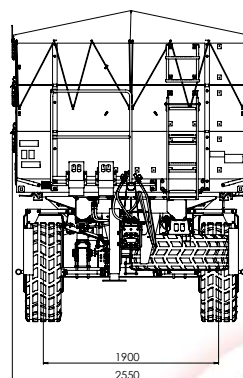
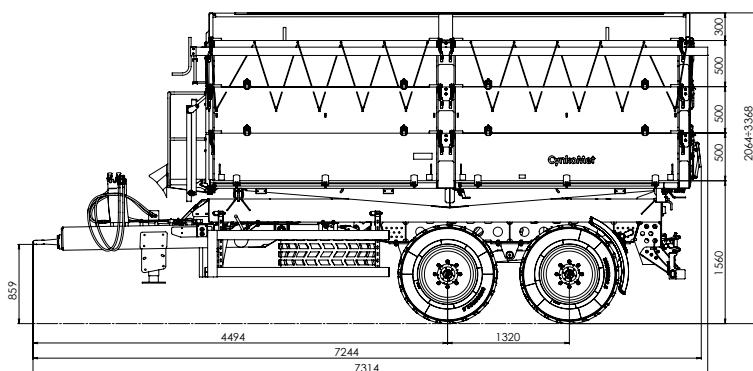

STANDARD MACHINE EQUIPMENT

Wall height 500 mm with thickness 2.5 mm, hot-galvanized

Partitioned side walls

New 385/65-22.5 wheels

Pallet width

Axles from the renowned ADR company, homologated (EU 2015/68), bar cross-section - square 90, brake size 406x120 412E, 8 M20x1.5 pins

Hot-galvanized, shock-absorbing drawbar, homologated according to EU Directive 2015/208, 50mm eye

Hydraulic drawbar support with built-in hydraulic lock

Central bolt-locking of walls (bottom sideboards)

Exterior ladder and steps inside cargo box - hot-galvanized - with anti-skid steps facilitating access to cargo box

Two wheel chocks placed in galvanized pockets

Telescopic actuator with articulated suspensions, five-level with 1980 mm pitch. Useful force at fifth level with diameter 140 mm, at nominal pressure 20MPa = 307.9kN (31.4T)

Tipping installation protected against excessive box inclination by cut-off valve

Maintenance support of cargo box, hot-galvanized

Side wall links

12V lighting, homologated, rear bulb lamps, LED perimeter lighting, rear socket for connection to second trailer

Lighting installation connector cable with 7PIN 12V plug

Homologated, double-circuit, pneumatic brake system with automatic braking force adjustment from HALDEX, with output for second trailer.

Parking handbrake with crank

Hot-galvanized frame of cargo box

Main stringers of cargo box frame made of closed profiles with variable cross-section, made from 6mm sheet. Profile cross-section at highest point 110x300 mm

Grain chute, hot-galvanized, with blockade in the rear wall

Hot-dip galvanized bottom frame (protection of the structure on the exterior and interior of profiles), stringers of the frame made of 250x150x8 closed sections

Rear hydraulic and brake output to the second trailer

Hydraulic tipping installation of cargo box made of galvanized steel tubes and flexible hoses

Hydraulic connectors to tractor, type ISO 7241-1 DN 12.5

Hot-galvanized rear bumper, homologated according to Regulations 2015/504 and 167/2013

All of our agricultural machines are designed and tested by our design team using the latest available tools. Manufacturing is performed with the greatest diligence and in adherence to rigorous quality standards.

OPTIONAL MACHINE EQUIPMENT
Structural elements
Set of hot-galvanized 500 mm wall extensions, thickness 2.5 mm
Spare wheel winch with hot-galvanized wheel hanger
Hot-galvanized tarpaulin frame made of 40x40x3 closed profiles
Chute for precise tipping, hot-galvanized
Hot-galvanized work platform
Side underrun guards
Ball hitch tension member dia. 80
Installations
Full LED lighting
Homologated, hydraulic double-circuit brake system with automatic braking force adjustment
Driving system
Surcharge for 550/60 R22.5 wheels
385/65 R22.5 spare wheel
550/60 R22.5 spare wheel
Other equipment
Roll-up tarpaulin
Manual hitch for second trailer
Automatic hitch for second trailer
Water tank + soap dispenser
Toolbox
Warning triangle (sign distinguishing slow-moving vehicle)
Hydraulic quick-coupler with pressure neutralizer in hose
DUPLEX - painted set of walls
DUPLEX - painted set of extensions

The data and photographs given in the catalog are for illustrative purposes only. This document and the information it contains, including prices, do not constitute a commercial offer within the meaning of art. 66 of the Civil Code. This information may be subject to change as products are continuously improved. The manufacturer reserves the right to change a product's characteristics at any time. Products' specifications may change without notice.



**HOT-
GALVANIZED CONSTRUCTION**