

NRN "Aligator" MANURE SPREADER

TECHNICAL SPECIFICATIONS | EQUIPMENT

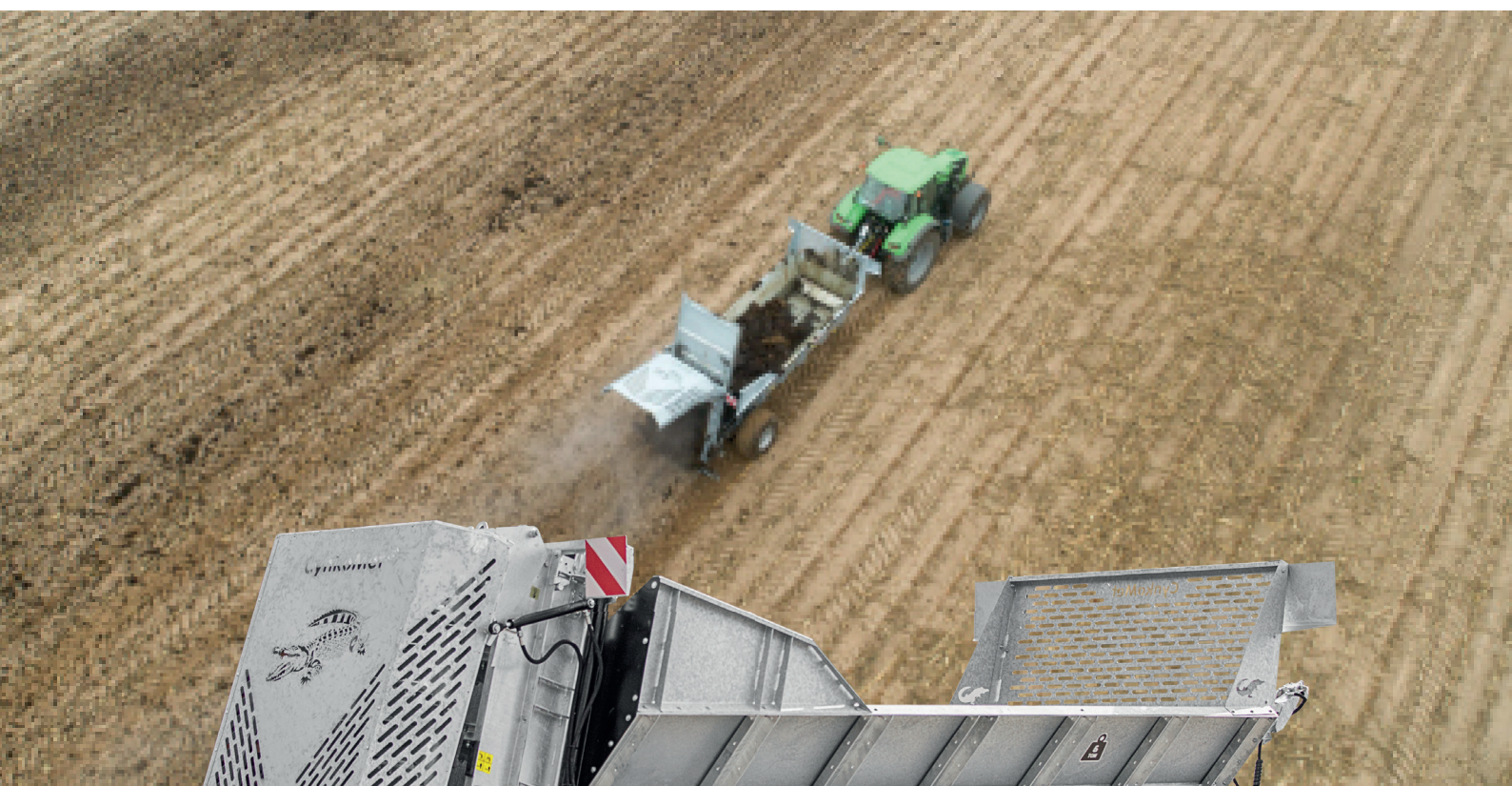

Year of model 2022

version.1.2022

CynkoMet[®]
Czarna Białostocka

TECHNICAL SPECIFICATIONS

PRICE	1 axle 128,000 PLN	TANDEM 124,000 PLN
Load capacity	~8000 kg*	
Gross vehicle weight rating	12,400 kg	12,450 kg
Unladen mass	~4400 kg*	~4450 kg*
Length	8,610 mm	
Width	2,970 mm	
Height	2,850 mm	
Width of cargo box interior (top/bottom)	1,480 mm / 2,120 mm	
Box wall height	950 mm	
Floor/wall sheet thickness	3 mm	
Height of platform from base	~ 1,000 mm	

DETAILED SPECIFICATIONS

Flat/Heap cargo capacity	~7.7 / ~10.7 m ³	
Track of wheels	2,350 mm	2,300 mm
Drawbar coupling height	~350 mm	
Max. tolerable vertical load on drawbar	3,000 (4,000)*** kg	
Max. tolerable load on driving axle	10,000 kg	10,550 kg
Suspension	parabolic spring	
Tire size	550/60-22.5	400/60-15.5
Design speed	40 km/h	
Minimum demand for tractor power	90 HP	95 HP
Spreading width	~10-16 m**	

* - unladen mass and loading capacity may vary depending on equipment

** - spreading width may differ from the specified width depending on the material used

*** - with K80 ball hitch

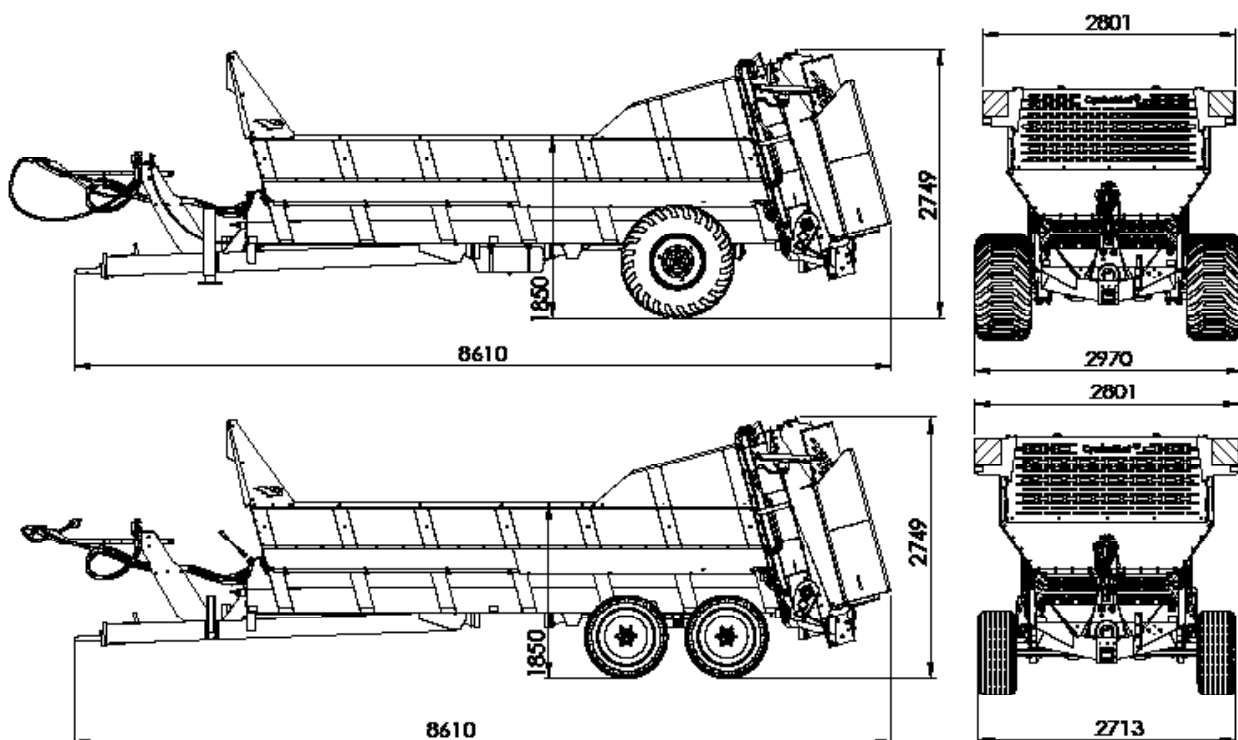

STANDARD MACHINE EQUIPMENT

Structural elements

Hot-galvanized rear hydraulic wall raised by two actuators with pitch 1600 mm

Exchangeable, galvanized skids of floor conveyor strips

Exchangeable screw-fastened floor made of hot-galvanized flat sheet, 3 mm thick

The hot-dip galvanized floor and walls, made of S355 steel sheet 3 mm thick

Wall height 895 mm

A2V adapter - balanced vertical drums with replaceable galvanized blades

Hydraulic floor conveyor drive

Hot-galvanized hydraulic rear wall

Hot-galvanized frame (profiles protected on exterior and interior)

Hydraulic drawbar support

Hot-galvanized 14x50 conveyor chain

Exchangeable, hot-galvanized conveyor strips made of metallurgical C65 profile

Exchangeable bottom slides of the conveyor made of oak strips, limiting noise during work

Star wheels made of spheroidal graphite iron

Floor conveyor powered by two transmissions, 4000 Nm each

Installations

Lighting installation connector cable with 7PIN 12V plug

12V lighting, homologated, with bulbs, LED perimeter lighting

Pneumatic, double-circuit brake system with automatic braking force adjustment from HALDEX.

Hydraulic advance of conveyor with stepless regulation and overload valve

Hydraulic installations made of galvanized steel tubes and flexible hoses

Hydraulic connectors to tractor, type ISO 7241-1 DN 12.5

Driving system

New 550/60-22.5 wheels (1 axle), 400/60-15.5 wheels (tandem)

Axles from renowned company - ADR

Other elements

Two wheel chocks placed in galvanized pockets

Drive shafts coupled to articulated PTO shafts equipped with clutches protecting the transmission: friction and one-way clutches.

*All of our agricultural machines are designed and tested by our design team using the latest available tools.
Manufacturing is performed with the greatest diligence and in adherence to rigorous quality standards.*

OPTIONAL MACHINE EQUIPMENT

Wide-angle articulated shaft

Warning triangle

600/50-22.5 wheels (1 axle)

500/50-17 wheels (tandem)

550/60-22.5 spare wheel

600/50-22.5 spare wheel

400/60-15.5 spare wheel

500/50-17 spare wheel



The data and photographs given in the catalog are for illustrative purposes only. This document and the information it contains, including prices, do not constitute a commercial offer within the meaning of art. 66 of the Civil Code. This information may be subject to change as products are continuously improved. The manufacturer reserves the right to change the product's characteristics at any time. Product specifications may change without prior notice.



**HOT-
GALVANIZED CONSTRUCTION**

CynkoMet®
Czarna Białostocka