

TRAILER T-169/1

TECHNICAL SPECIFICATIONS | EQUIPMENT



Year of model 2022

CynkoMet[®]
Czarna Białostocka

TECHNICAL SPECIFICATIONS	
Type / Variant / Version according to EU homologation	T-1 121 21
Administrative loading capacity	~ 3,920 kg*
Technical loading capacity	~ 4,000 kg*
Gross vehicle weight rating according to PL regulations	6,200 kg
Gross vehicle weight rating according to Directive 2015/208 (only load on axles)	6,200 kg
Kerb weight (without wall extensions)	~ 2,280 kg*
Number of axles	2
Length	6,170 mm
Width	2,300 mm
Height without extensions	1,600 mm
Height with extensions	2,100 mm
Length of cargo box interior	4,040 mm
Width of cargo box interior front/rear	2,090 / 2,140 mm
Height of box walls (without extensions)	500 mm
Height of platform from base	1,100 mm
Floor/wall sheet thickness	4 / 2.5 mm
Loading surface	8.6 m ²
Loading capacity - without extensions / with extensions	4.3 m ³ (8.6 m ³)
Track of wheels	1,700 mm
Wheelbase	2,670 mm
Suspension	parabolic springs
Drawbar coupling height - min.	320 mm
Drawbar coupling height - max.	1,020 mm
Max. tolerable vertical load on axle	1. 3100 kg 2. 3,100 kg
Tire size	10/75-15.3
Design speed	40 km/h
Minimum demand for tractor power	36.8 kW / 50 HP
Tipping angle of the cargo box (backward / sideways)	45 / 50
Tipping system	three-way

* - unladen weight and loading capacity may differ depending on the trailer's equipment

STANDARD MACHINE EQUIPMENT
Wall height 500 mm with thickness 2.5 mm, hot-galvanized
Central bolt-locking of walls (bottom sideboards)
Exterior ladder and steps inside cargo box - hot-galvanized - with anti-skid steps facilitating access to cargo box
Maintenance support of cargo box, hot-galvanized
"Triangle" drawbar - drawbar homologated according to Reg. 55UN ECE
Welded hitch tension member dia. 40
Hot-galvanized frame of cargo box
Main stringers of cargo box frame made of metallurgical 160 channel sections
Galvanized cargo box floor made of single riveted and bolted sheet, thickness 4mm
Hot-dip galvanized bottom frame (protection of the structure on the exterior and interior of profiles), stringers of the frame made of metallurgical 160 and 140 channel sections, additionally closed by 5 mm sheet
Parking handbrake with crank
Grain chute, hot-galvanized, with blockade in the rear wall
Regulated spring supporting drawbar
Homologated, hot-galvanized bumper
Side wall links
Rear hitch for second trailer
Tipping installation protected against excessive box inclination by cut-off valve
Lighting installation connector cable with 7PIN 12V plug
12V lighting, homologated, rear bulb lamps, LED perimeter lighting
Hydraulic tipping installation of cargo box made of galvanized steel tubes and flexible hoses
Hydraulic connectors to tractor, type ISO 7241-1 DN 12.5
Homologated, double-circuit, pneumatic brake system with automatic braking force adjustment, with output for second trailer.
Rear hydraulic, electrical and brake output to the second trailer
New 10/75-15.3 wheels
Axles from renowned ADR company, full beam with 80mm square cross-section, 300x90 brake
Parabolic leaf spring suspension
Two wheel chocks placed in galvanized pockets
Telescopic actuator with articulated suspensions, four-level with 1,300 mm pitch. Useful force at fourth level with diameter 105mm, at nominal pressure 16MPa = 138kN (~14T)
Wheel fenders

All of our agricultural machines are designed and tested by our design team using the latest available tools. Manufacturing is performed with the greatest diligence and in adherence to rigorous quality standards.

OPTIONAL MACHINE EQUIPMENT
Spare wheel hanger, hot-galvanized
Hot-galvanized tarpaulin frame made of 40x40x3 closed profiles
Hot-galvanized 500 mm wall extensions, thickness 2.5 mm
Chute for precise tipping, hot-galvanized
Hot-galvanized work platform
Full LED lighting
Homologated, hydraulic double-circuit brake system with automatic braking force adjustment
Surcharge for 14/65-16 wheels
Surcharge for 11.5/80-15.3 wheels
14/65-16 spare wheel
10/75-15.3 spare wheel
11.5/80-15.3 spare wheel
Other equipment
Laced tarpaulin
Roll-up tarpaulin
Hydraulic quick-coupler with pressure neutralizer in hose
Warning triangle (sign distinguishing slow-moving vehicle)
DUPLEX - painted set of walls
DUPLEX - painted set of extensions
Drawbar eye 50mm
Set of side (bicycle) guards

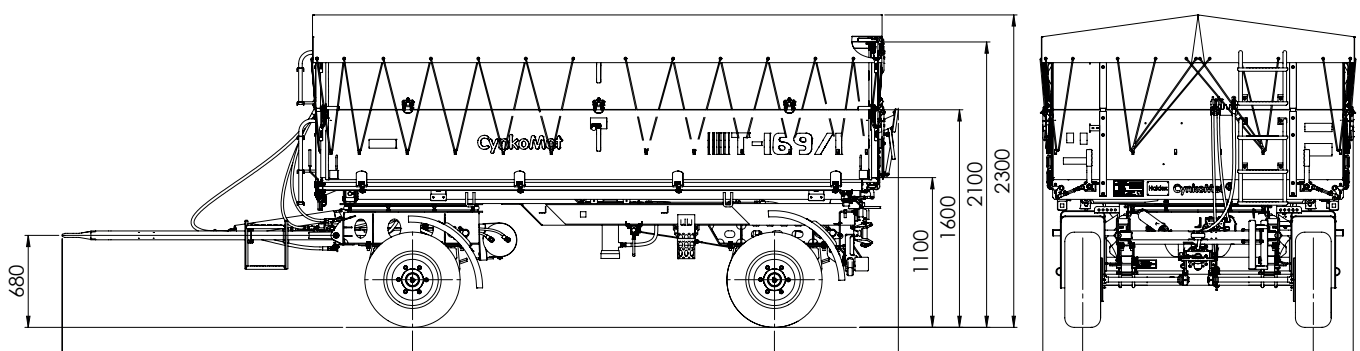

The data and photographs given in the catalog are for illustrative purposes only. This document and the information it contains, including prices, do not constitute a commercial offer within the meaning of art. 66 of the Civil Code. This information may be subject to change as products are continuously improved. We reserve the right to change a product's characteristics at any time. Products' specifications may change without notice. Realization of an order begins when a person from our sales department confirms the data contained in the order form.

The time at which a contract is concluded is the moment of acceptance of an offer by the CynkoMet Sp. z o.o. salesperson.