

TRAILER T-104-4

TECHNICAL SPECIFICATIONS | EQUIPMENT



 **HOMOLOGATION
EUROPEAN**



Year of model 2022

CynkoMet[®]
Czarna Białostocka

TECHNICAL SPECIFICATIONS	
Type / Variant / Version according to EU homologation	T-1 621 41
Administrative loading capacity	~8100 kg*
Technical loading capacity	~8100 kg*
Gross vehicle weight rating according to PL regulations	~11,000 kg
Gross vehicle weight rating according to Directive 2015/208 (only load on axles)	~11,000 kg
Kerb weight (without wall extensions)	~2900 kg*
Number of axles	2
Length	6,520 mm
Width	2,440 mm
Height without extensions	1,770 mm
Height with extensions	2,270 mm
Box type	Side-wall, not pallet type
Length of cargo box interior	4,440 mm
Width of cargo box interior front/rear	2,245 / 2,295 mm
Height of box walls (without extensions)	500 mm
Height of platform from base	1,270 mm
Floor/wall sheet thickness	5 / 2.5 mm
Loading surface	10 m ²
Loading capacity - without extensions (with extensions)	5 m ³ (10 m ³)
Track of wheels	1,800 mm
Wheelbase	3,000 mm
Suspension	parabolic springs
Drawbar coupling height - min.	400 mm
Drawbar coupling height - max.	1,100 mm
Max. tolerable vertical load on axle	1. 5500 kg 2. 5,500 kg
Tire size	500/50-17
Design speed	40 km/h
Minimum demand for tractor power	51.5 kW / 70 HP
Tipping angle of the cargo box (backward / sideways)	45 / 50
Tipping system	three-way

* - unladen weight and loading capacity may differ depending on the trailer's equipment

STANDARD MACHINE EQUIPMENT

Wall height 500 mm with thickness 2.5 mm, hot-galvanized

Central bolt-locking of walls (bottom sideboards)

Exterior ladder and steps inside cargo box - hot-galvanized - with anti-skid steps facilitating access to cargo box

Maintenance support of cargo box, hot-galvanized

“Triangle” drawbar - drawbar homologated according to Reg. 55 UN ECE)

Welded hitch tension member dia. 40

Hot-galvanized frame of cargo box

Main stringers (with variable cross-section) of cargo box frame made of bent high-strength sheets

Galvanized cargo box floor welded out of two sheets with a thickness of 5 mm, bolted and riveted

Hot-dip galvanized bottom frame (protection of the structure on the exterior and interior of profiles), stringers of the frame made of 200x80x6 and 160x80x6 closed sections

Parking handbrake with crank

Grain chute, hot-galvanized, with blockade in the rear wall

Regulated spring supporting drawbar

Homologated, hot-galvanized bumper

Side wall links

Tipping installation protected against excessive box inclination by cut-off valve

Lighting installation connector cable with 7PIN 12V plug

12V lighting, homologated, rear bulb lamps, LED perimeter lighting

Hydraulic tipping installation of cargo box made of galvanized steel tubes and flexible hoses

Hydraulic connectors to tractor, type ISO 7241-1 DN 12.5

Homologated, double-circuit, pneumatic brake system with automatic braking force adjustment, with output for second trailer.

Rear hydraulic, electrical and brake output to the second trailer

New 500/50-17 wheels

Axles from renowned ADR company, full beam with 80 mm square cross-section, 350x90 brake

Parabolic leaf spring suspension

Two wheel chocks placed in galvanized pockets

Telescopic actuator with articulated suspensions, four-level with 1700 mm pitch. Useful force at fourth level with diameter 120 mm, at nominal pressure 16 MPa = 180 kN (~18.3T)

Wheel fenders

All of our agricultural machines are designed and tested by our design team using the latest available tools. Manufacturing is performed with the greatest diligence and in adherence to rigorous quality standards.

OPTIONAL MACHINE EQUIPMENT

Structural elements

Spare wheel hanger with winch, hot-galvanized

Hot-galvanized tarpaulin frame made of 40x40x3 closed profiles

Hot-galvanized 500 mm wall extensions, thickness 2.5 mm

Chute for precise tipping, hot-galvanized

Hot-galvanized work platform

Full LED lighting

Homologated, hydraulic double-circuit brake system with automatic braking force adjustment

500/50-17 spare wheel

Laced tarpaulin

Roll-up tarpaulin

Hydraulic quick-coupler with pressure neutralizer in hose

Warning triangle (sign distinguishing slow-moving vehicle)

DUPLEX - painted set of walls

DUPLEX - painted set of extensions

Drawbar eye 50mm

Automatic hitch for second trailer

Manual hitch for second trailer

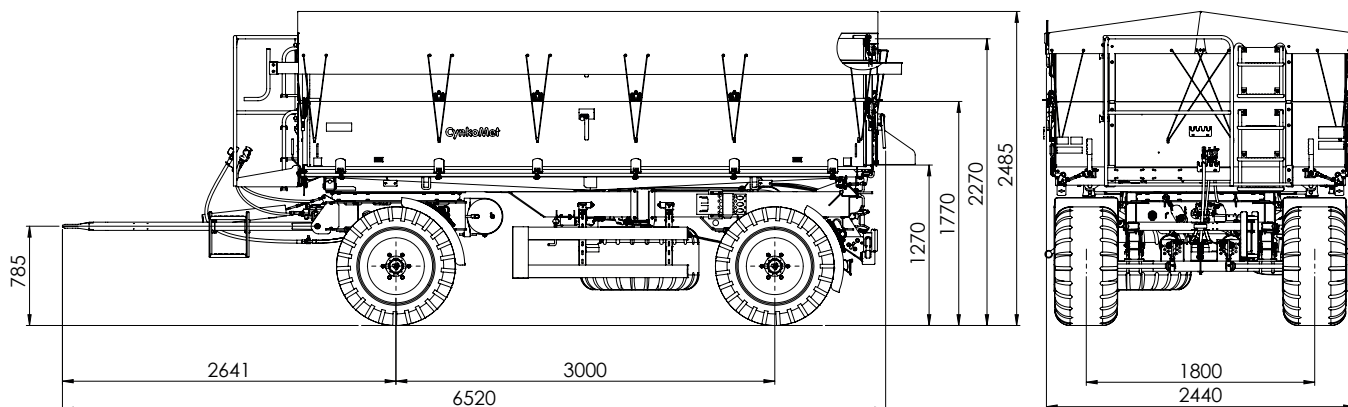

The data and photographs given in the catalog are for illustrative purposes only. This document and the information it contains, including prices, do not constitute a commercial offer within the meaning of art. 66 of the Civil Code. This information may be subject to change as products are continuously improved. We reserve the right to change a product's characteristics at any time.

Products' specifications may change without notice. Realization of an order begins when a person from our sales department confirms the data contained in the order form.



HOT-GALVANIZED CONSTRUCTION

CynkoMet®
Czarna Białostocka